

**MAS9123****80 mA LDO Voltage Regulator IC**

- **Very Low Noise: 9.5  $\mu$ Vrms**
- **Very Short Start-up Time: 20  $\mu$ s**
- **Excellent Ripple Rejection: 68 dB**
- **Stable with Low-ESR Output Capacitors**
- **Low Minimum Output Capacitance Requirement: 0.23  $\mu$ F**
- **Regulator Enable/Disable Control**

**DESCRIPTION**

MAS9123 is a low dropout voltage regulator with an enable/disable pin, which allows device to be turned off or on by pulling control to low or high.

Due to the very low noise level of only 9.5  $\mu$ Vrms MAS9123 is highly suitable for very sensitive circuits, e.g., in portable applications. In addition to the noise level, MAS9123 excels in dropout voltage (95 mV typical at 50 mA) and in start-up time (with bypass capacitor typically 20  $\mu$ s from start-up to within  $\pm 1\%$  of  $V_{OUT(NOM)}$ ). Also its ripple rejection ability of 68 dB at 10 kHz exceed that of competition.

The Equivalent Series Resistance (ESR) range of output capacitors that can be used with MAS9123 is very wide. This ESR range from a few m $\Omega$  up to a couple of Ohms combined with no minimum output

current requirement makes the usage of MAS9123 easier and low in cost. Also the minimum output capacitance requirement is very low. This combined with very short start-up time makes it possible to switch the regulator off and on even in timing critical and/or noise sensitive applications.

MAS9123 also includes an auto-discharge function, wherein a shutdown transistor turns on and discharges the output capacitor, when MAS9123 is turned off.

An internal thermal protection circuit prevents the device from overheating. Also the maximum output current is internally limited. In order to save power the device goes into sleep mode when the regulator is disabled.

**FEATURES**

- Optimized for Fast Start-up
- Very Low Noise
- Internal Thermal Shutdown
- Short Circuit Protection
- Functionally and Pin Compatible with LP2982/LP2985/LP3985
- Small SOT23-5 or tiny WL-CSP Package
- Output Voltage Options: 2.8, 3.0 and 3.3 V, see Ordering Information p. 12

**APPLICATIONS**

- RF Oscillators
- GPS Systems
- RF Section of Wireless Systems
- RF Section of Cellular Phones
- Oven Oscillators
- RF Section of Cordless Phones
- Battery Powered Systems
- Portable Systems
- Radio Control Systems

## PIN CONFIGURATION

### SOT23-5

Top View

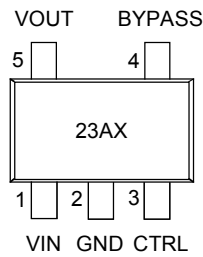

For top marking information see ordering information p. 12

### WL-CSP

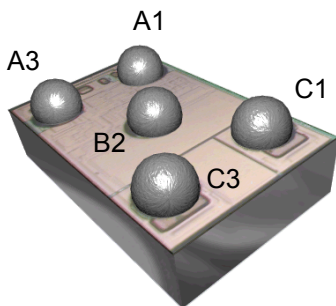

BOTTOM VIEW

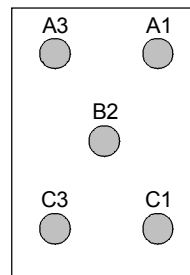

TOP VIEW

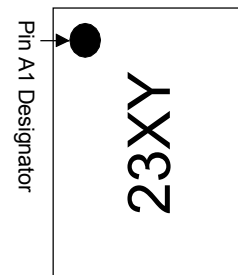

For top marking information see ordering information p. 12

## PIN DESCRIPTION

Pin Name	Pin Number in SOT23-5	Pin Number in WL-CSP		Type	Function
		Pin Order 11 Note 1	Pin Order 12 Note 2		
VIN	1	C3	C3	P	Power Supply Voltage
GND	2	B2	A1	G	Ground
CTRL	3	A1	A3	I	Enable/Disable Pin for Regulator
BYPASS	4	A3	B2	I	Pin for Bypass Capacitor
VOUT	5	C1	C1	O	Output

G = Ground, I = Input, O = Output, P = Power

**Note 1:** WL-CSP Pin Order 11 is pin compatible with LP3985.

**Note 2:** WL-CSP Pin Order 12 is pin compatible with LP2985.

## BLOCK DIAGRAM

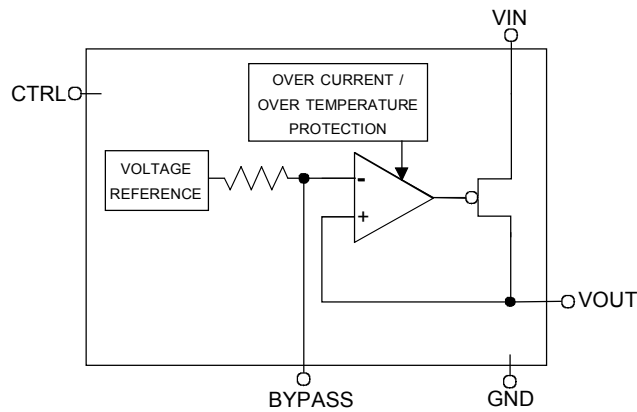

## ABSOLUTE MAXIMUM RATINGS

All voltages with respect to ground.

Parameter	Symbol	Conditions	Min	Max	Unit
Supply Voltage	$V_{IN}$		-0.3	6	V
Voltage Range for All Pins			-0.3	$V_{IN} + 0.3$	V
ESD Rating		HBM		2	kV
Junction Temperature	$T_{Jmax}$			+175 (limited)	°C
Storage Temperature	$T_S$		-55	+150	°C

Stresses beyond those listed may cause permanent damage to the device. The device may not operate under these conditions, but it will not be destroyed.

## RECOMMENDED OPERATING CONDITIONS

Parameter	Symbol	Conditions	Min	Max	Unit
Operating Junction Temperature	$T_J$		-40	+125	°C
Operating Ambient Temperature	$T_A$		-40	+85	°C
Operating Supply Voltage	$V_{IN}$		2.5	5.3	V

## ELECTRICAL CHARACTERISTICS

### ◆ Thermal Protection

$T_A = -40^{\circ}\text{C}$  to  $+85^{\circ}\text{C}$ , typical values at  $T_A = +27^{\circ}\text{C}$ ,  $V_{IN} = V_{OUT(NOM)} + 1.0\text{ V}$ ,  $I_{OUT} = 1.0\text{ mA}$ ,  $C_{IN} = 1.0\text{ }\mu\text{F}$ ,  $C_L = 1.0\text{ }\mu\text{F}$ ,  $C_{BYPASS} = 10\text{ nF}$ ,  $V_{CTRL} = 2.0\text{ V}$ , unless otherwise specified.

Parameter	Symbol	Conditions	Min	Typ	Max	Unit
Threshold High	$T_H$		145	160	175	$^{\circ}\text{C}$
Threshold Low	$T_L$		135	150	165	$^{\circ}\text{C}$

The hysteresis of  $10^{\circ}\text{C}$  prevents the device from turning on too soon after thermal shut-down.

### ◆ Control Terminal Specifications

$T_A = -40^{\circ}\text{C}$  to  $+85^{\circ}\text{C}$ , typical values at  $T_A = +27^{\circ}\text{C}$ ,  $V_{IN} = V_{OUT(NOM)} + 1.0\text{ V}$ ,  $I_{OUT} = 1.0\text{ mA}$ ,  $C_{IN} = 1.0\text{ }\mu\text{F}$ ,  $C_L = 1.0\text{ }\mu\text{F}$ ,  $C_{BYPASS} = 10\text{ nF}$ ,  $V_{CTRL} = 2.0\text{ V}$ , unless otherwise specified.

Parameter	Symbol	Conditions	Min	Typ	Max	Unit
Control Voltage OFF State ON State	$V_{CTRL}$		-0.3 1.6		0.55 $V_{IN} + 0.3$	V
Control Current	$I_{CTRL}$	$V_{CTRL} = V_{IN}$ $V_{CTRL} = 0\text{ V}$		5 0	15	$\mu\text{A}$

If CTRL-pin is not connected, MAS9123 is in OFF state (900 k $\Omega$  pull-down resistor to ground).

### ◆ Voltage Parameters

$T_A = -40^{\circ}\text{C}$  to  $+85^{\circ}\text{C}$ , typical values at  $T_A = +27^{\circ}\text{C}$ ,  $V_{IN} = V_{OUT(NOM)} + 1.0\text{ V}$ ,  $I_{OUT} = 1.0\text{ mA}$ ,  $C_{IN} = 1.0\text{ }\mu\text{F}$ ,  $C_L = 1.0\text{ }\mu\text{F}$ ,  $C_{BYPASS} = 10\text{ nF}$ ,  $V_{CTRL} = 2.0\text{ V}$ , unless otherwise specified.

Parameter	Symbol	Conditions	Min	Typ	Max	Unit
Output Voltage Tolerance	$V_{OUT}$	$I_{OUT} = 0\text{ mA}$ $I_{OUT} = 50\text{ mA}$	$V_{OUT(NOM)} - 0.05$ $V_{OUT(NOM)} - 0.10$		$V_{OUT(NOM)} + 0.05$ $V_{OUT(NOM)} + 0.05$	V
Dropout Voltage	$V_{DROP}$	$I_{OUT} = 1\text{ mA}$ $I_{OUT} = 10\text{ mA}$ $I_{OUT} = 50\text{ mA}$		46 51 95		mV

### ◆ Current Parameters

$T_A = -40^{\circ}\text{C}$  to  $+85^{\circ}\text{C}$ , typical values at  $T_A = +27^{\circ}\text{C}$ ,  $V_{IN} = V_{OUT(NOM)} + 1.0\text{ V}$ ,  $I_{OUT} = 1.0\text{ mA}$ ,  $C_{IN} = 1.0\text{ }\mu\text{F}$ ,  $C_L = 1.0\text{ }\mu\text{F}$ ,  $C_{BYPASS} = 10\text{ nF}$ ,  $V_{CTRL} = 2.0\text{ V}$ , unless otherwise specified.

Parameter	Symbol	Conditions	Min	Typ	Max	Unit	
Continuous Output Current	$I_{OUT}$		0		80	mA	
Short Circuit Current	$I_{MAX}$	$R_L = 0\text{ }\Omega$		230		mA	
Peak Output Current	$I_{PK}$	$V_{OUT} > 95\% * V_{OUT(NOM)}$		180		mA	
Ground Pin Current	$I_{GND}$	$I_{OUT} = 0\text{ mA}$ $I_{OUT} = 10\text{ mA}$ $I_{OUT} = 50\text{ mA}$		170 210 250		$\mu\text{A}$	
Ground Pin Current, Sleep mode	$I_{GND}$	$V_{CTRL} = 0\text{ V}$	$T_A = 27^{\circ}\text{C}$		0.02	0.5	$\mu\text{A}$
			$T_A = 85^{\circ}\text{C}$		0.2	2	

◆ **Power Dissipation**

$T_A = -40^{\circ}\text{C}$  to  $+85^{\circ}\text{C}$ , typical values at  $T_A = +27^{\circ}\text{C}$ ,  $V_{IN} = V_{OUT(NOM)} + 1.0\text{ V}$ ,  $I_{OUT} = 1.0\text{ mA}$ ,  $C_{IN} = 1.0\text{ }\mu\text{F}$ ,  $C_L = 1.0\text{ }\mu\text{F}$ ,  $C_{BYPASS} = 10\text{ nF}$ ,  $V_{CTRL} = 2.0\text{ V}$ , unless otherwise specified.

Parameter	Symbol	Conditions	Min	Typ	Max	Unit
Thermal Resistance (Junction-to-Air)	$R_{JA}$	thermal test board according to JESD51-7 (4 layers), SOT23-5 package		191		$^{\circ}\text{C/W}$
		mounted on MAS9123 CSP evaluation board, WL-CSP package		210		
Maximum Power Dissipation	$P_d$	any ambient temperature	$P_{dMAX} = \frac{T_{J(MAX)} - T_A}{R_{JA}}$			W

**Note 1:**  $T_{J(MAX)}$  denotes maximum operating junction temperature ( $+125^{\circ}\text{C}$ ),  $T_A$  ambient temperature, and  $R_{JA}$  junction-to-air thermal resistance specified above.

◆ **Line and Load Regulation**

$T_A = -40^{\circ}\text{C}$  to  $+85^{\circ}\text{C}$ , typical values at  $T_A = +27^{\circ}\text{C}$ ,  $V_{IN} = V_{OUT(NOM)} + 1.0\text{ V}$ ,  $I_{OUT} = 1.0\text{ mA}$ ,  $C_{IN} = 1.0\text{ }\mu\text{F}$ ,  $C_L = 1.0\text{ }\mu\text{F}$ ,  $C_{BYPASS} = 10\text{ nF}$ ,  $V_{CTRL} = 2.0\text{ V}$ , unless otherwise specified.

Parameter	Symbol	Conditions	Min	Typ	Max	Unit
Line Regulation		$V_{OUT(NOM)} + 1\text{ V} < V_{IN} < 5.3\text{ V}$ , $I_{OUT} = 50\text{ mA}$		0.75	2	mV
Load Regulation		$I_{OUT} = 1.0$ to $50\text{ mA}$		13.5	25	mV

◆ **Noise and Ripple Rejection**

$T_A = -40^{\circ}\text{C}$  to  $+85^{\circ}\text{C}$ , typical values at  $T_A = +27^{\circ}\text{C}$ ,  $V_{IN} = V_{OUT(NOM)} + 1.0\text{ V}$ ,  $I_{OUT} = 1.0\text{ mA}$ ,  $C_{IN} = 1.0\text{ }\mu\text{F}$ ,  $C_L = 1.0\text{ }\mu\text{F}$ ,  $C_{BYPASS} = 10\text{ nF}$ ,  $V_{CTRL} = 2.0\text{ V}$ , unless otherwise specified.

Parameter	Symbol	Conditions	Min	Typ	Max	Unit
Output Noise Voltage	$V_{RMS}$	$10\text{ Hz} < f < 100\text{ kHz}$		9.5		$\mu\text{Vrms}$
Noise Density	$V_N$	$I_{OUT} = 50\text{ mA}$ , $f = 10\text{ kHz}$		24		$\text{nV}/\sqrt{\text{Hz}}$
PSRR		$f = 1\text{ kHz}$		70		dB
		$f = 10\text{ kHz}$		68		
		$f = 100\text{ kHz}$		58		

◆ **Dynamic Parameters**

$T_A = -40^{\circ}\text{C}$  to  $+85^{\circ}\text{C}$ , typical values at  $T_A = +27^{\circ}\text{C}$ ,  $V_{IN} = V_{OUT(NOM)} + 1.0\text{ V}$ ,  $I_{OUT} = 1.0\text{ mA}$ ,  $C_{IN} = 1.0\text{ }\mu\text{F}$ ,  $C_L = 1.0\text{ }\mu\text{F}$ ,  $C_{BYPASS} = 10\text{ nF}$ ,  $V_{CTRL} = 2.0\text{ V}$ , unless otherwise specified.

Parameter	Symbol	Conditions	Min	Typ	Max	Unit
Start-up Delay (from start-up to 80% of $V_{OUT(NOM)}$ )		$V_{CTRL} = 0$ to $2.4\text{ V}$ , $I_{OUT} = 50\text{ mA}$ , $C_L \leq 1.0\text{ }\mu\text{F}$		7.5		$\mu\text{s}$
Overshoot		$V_{CTRL} = 0$ to $2.4\text{ V}$		1.0	8.0	%
Start-up Time (settling time of voltage transient from start-up to within $\pm 1\%$ of $V_{OUT(NOM)}$ )		$V_{CTRL} = 0$ to $2.4\text{ V}$ , $I_{OUT} = 50\text{ mA}$ , $C_L \leq 1.0\text{ }\mu\text{F}$		20		$\mu\text{s}$

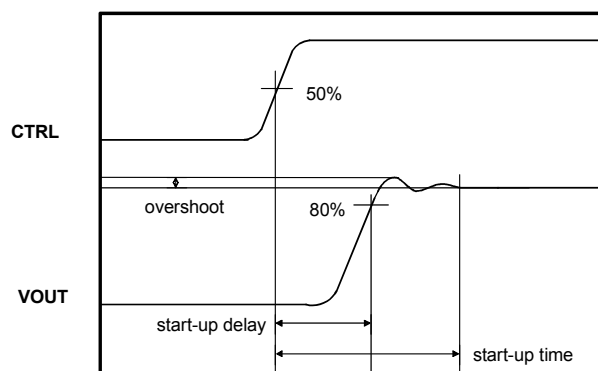

**Figure 1.** Definitions of start-up delay, overshoot and start-up time.

## TYPICAL PERFORMANCE CHARACTERISTICS

$T_A = +27^\circ\text{C}$ ,  $V_{IN} = V_{OUT(NOM)} + 1.0\text{ V}$ ,  $I_{OUT} = 50\text{ mA}$ ,  $C_{IN} = 1.0\ \mu\text{F}$ ,  $C_L = 1.0\ \mu\text{F}$ ,  $C_{BYPASS} = 10\text{ nF}$ ,  $V_{CTRL} = 2.0\text{ V}$ , unless otherwise specified.

### Start-up

MAS9123 start-up is optimized for bypass capacitor values of 3 to 20 nF. When values are lower than 3 nF the start-up settling might be unstable for about 20  $\mu\text{s}$  after the start-up. The rise time increases if bypass capacitor values are bigger than 20 nF.

### Start-up settling

Typically 20  $\mu\text{s}$  after the start-up the output voltage drops about 10 to 20 mV in 250  $\mu\text{s}$  time (figure 4).

The value of this voltage drop depends on the parasitic components of the bypass capacitor. After the voltage drop the output voltage rises slowly to the final value (figure 5).

### Noise reduction

MAS9123 has typically 9.5  $\mu\text{V}_{\text{RMS}}$  output noise with 10 nF bypass capacitor. By increasing the capacitance value, the output noise will slightly decrease, but the start-up time increases.

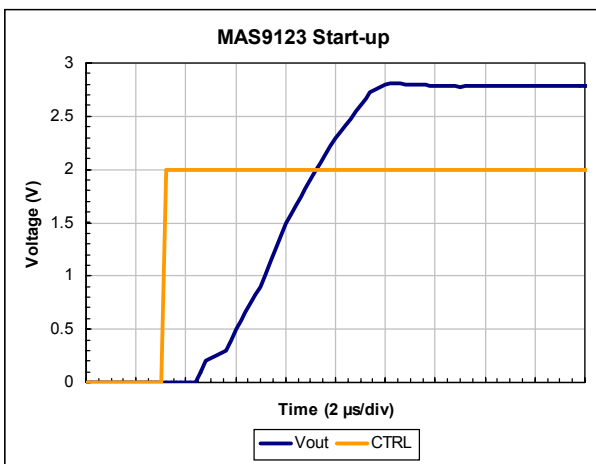

Figure 2. Typical start-up.

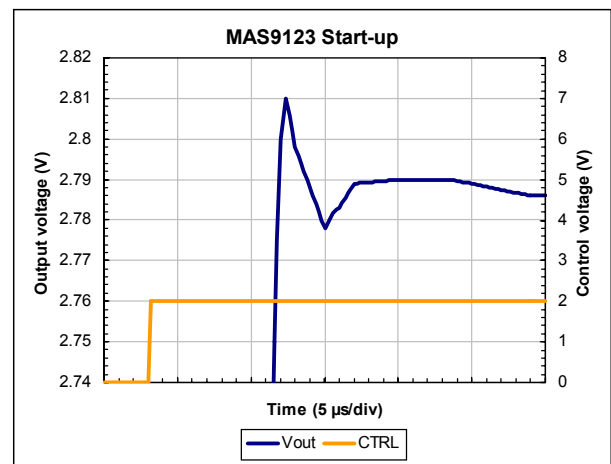

Figure 3. Typical start-up.

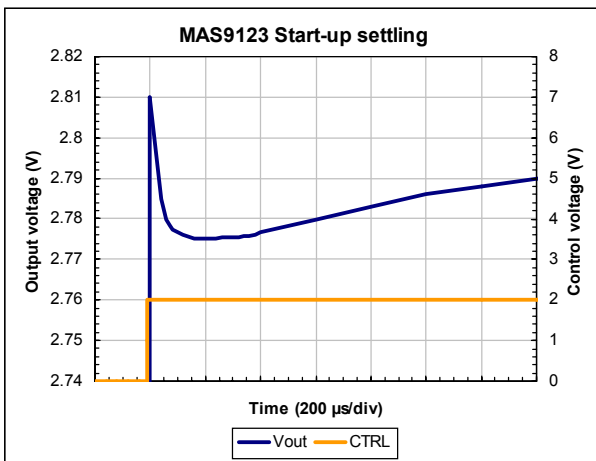

Figure 4. Typical start-up settling.

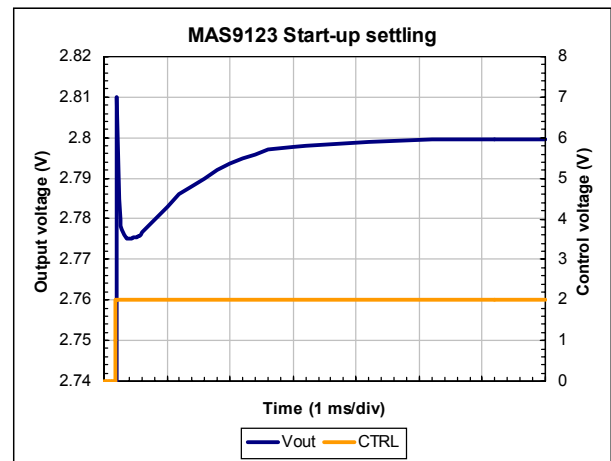
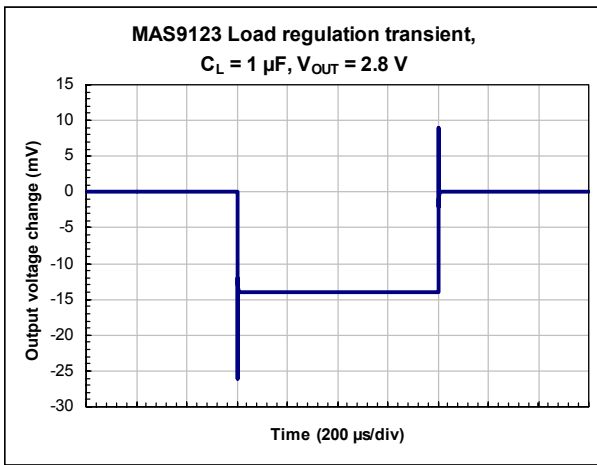

Figure 5. Typical start-up settling.

## TYPICAL PERFORMANCE CHARACTERISTICS

$T_A = +27^\circ\text{C}$ ,  $V_{IN} = V_{OUT(NOM)} + 1.0\text{ V}$ ,  $I_{OUT} = 50\text{ mA}$ ,  $C_{IN} = 1.0\ \mu\text{F}$ ,  $C_L = 1.0\ \mu\text{F}$ ,  $C_{BYPASS} = 10\text{ nF}$ ,  $V_{CTRL} = 2.0\text{ V}$ , unless otherwise specified.



**Figure 6.** Typical load regulation transient.  $C_L = 1\ \mu\text{F}$ ,  $I_{OUT} = 0.5\text{ mA} \dots 50\text{ mA}$  in  $2\ \mu\text{s}$ .

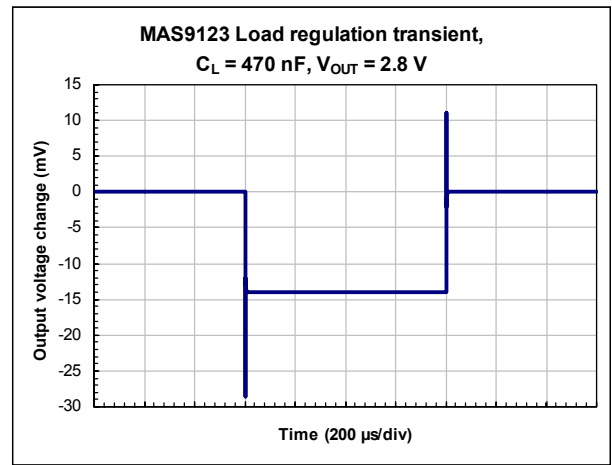

**Figure 7.** Typical load regulation transient.  $C_L = 470\text{ nF}$ ,  $I_{OUT} = 0.5\text{ mA} \dots 50\text{ mA}$  in  $2\ \mu\text{s}$ .

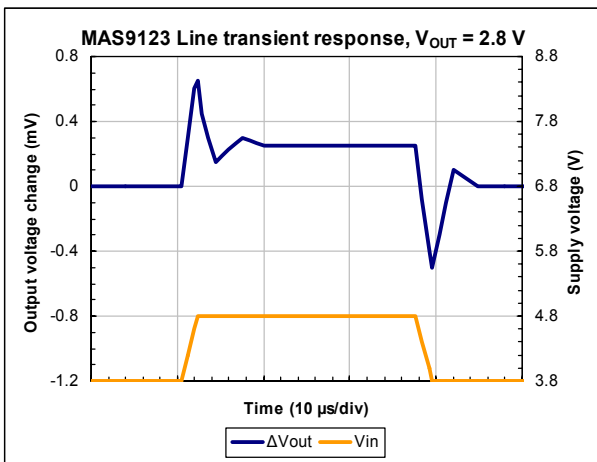

**Figure 8.** Line transient response.  $C_L = 1\ \mu\text{F}$ ,  $I_{OUT} = 10\text{ mA}$ .

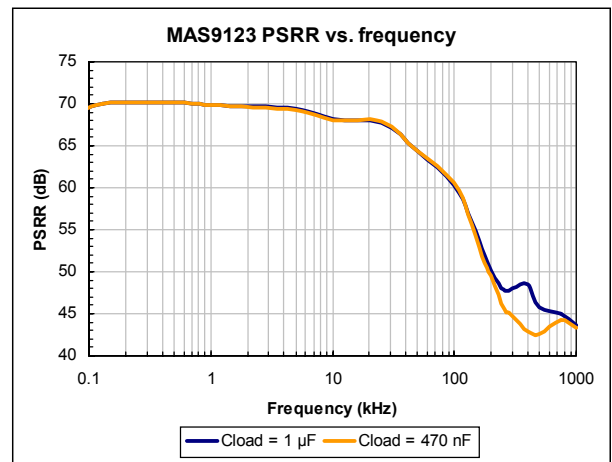

**Figure 9.** PSRR vs. frequency.

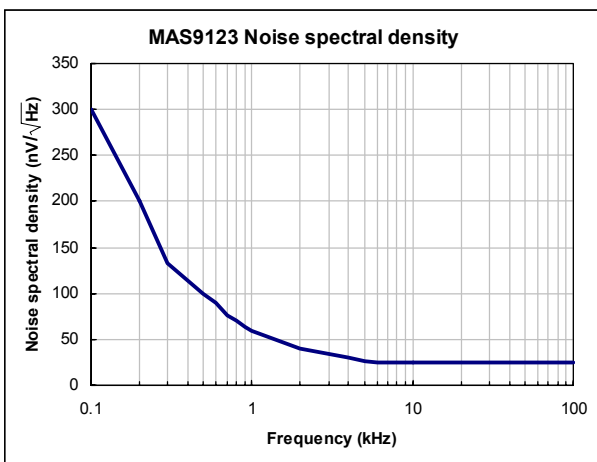

**Figure 10.** Noise spectral density vs. frequency.

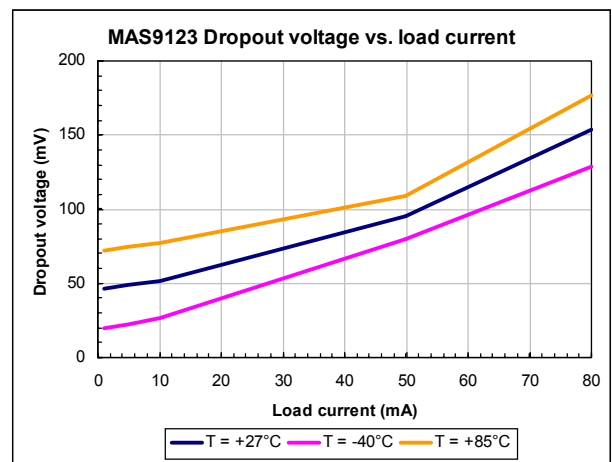

**Figure 11.** Dropout voltage vs. load current.

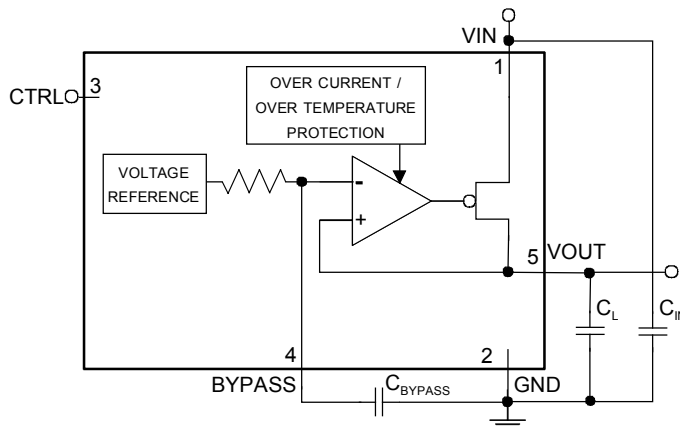
**APPLICATION INFORMATION**

**Auto-Discharge Function**

MAS9123 has a shutdown transistor that turns on, when the device is disabled, and discharges the output capacitor.

Parameter	Symbol	Min	Typ	Max	Unit	Note
Output Capacitance	$C_L$	0.23	1.0		$\mu\text{F}$	<ol style="list-style-type: none"> <li>1. Ceramic and film capacitors can be used.</li> <li>2. The value of <math>C_L</math> should be smaller than or equal to the value of <math>C_{IN}</math>.</li> </ol>
Effective Series Resistance	ESR	0.01		2	$\Omega$	<ol style="list-style-type: none"> <li>1. When within this range stable with all <math>I_{OUT} = 0 \text{ mA} \dots 80 \text{ mA}</math> values.</li> </ol>
Bypass Capacitance	$C_{BYPASS}$	3	10		nF	<ol style="list-style-type: none"> <li>1. Ceramic and film capacitors are best suited. For maximum output voltage accuracy DC leakage current through capacitor should be kept as low as possible. In any case DC leakage current must be below 100 nA.</li> </ol>
Input Capacitance	$C_{IN}$	0.5			$\mu\text{F}$	<ol style="list-style-type: none"> <li>1. A big enough input capacitance is needed to prevent possible impedance interactions between the supply and MAS9123.</li> <li>2. Ceramic, tantalum, and film capacitors can be used. If a tantalum capacitor is used, it should be checked that the surge current rating is sufficient for the application.</li> <li>3. In the case that the inductance between a <b>battery</b> and MAS9123 is very small (<math>&lt; 0.1 \mu\text{H}</math>), a <math>0.47 \mu\text{F}</math> input capacitor is sufficient.</li> <li>4. The value of <math>C_{IN}</math> should not be smaller than the value of <math>C_L</math>.</li> </ol>

Values given on the table are minimum requirements unless otherwise specified. When selecting capacitors, tolerance and temperature coefficient must be considered to **make sure that the requirement is met in all potential operating conditions.**



**PACKAGE (SOT23-5) OUTLINE**

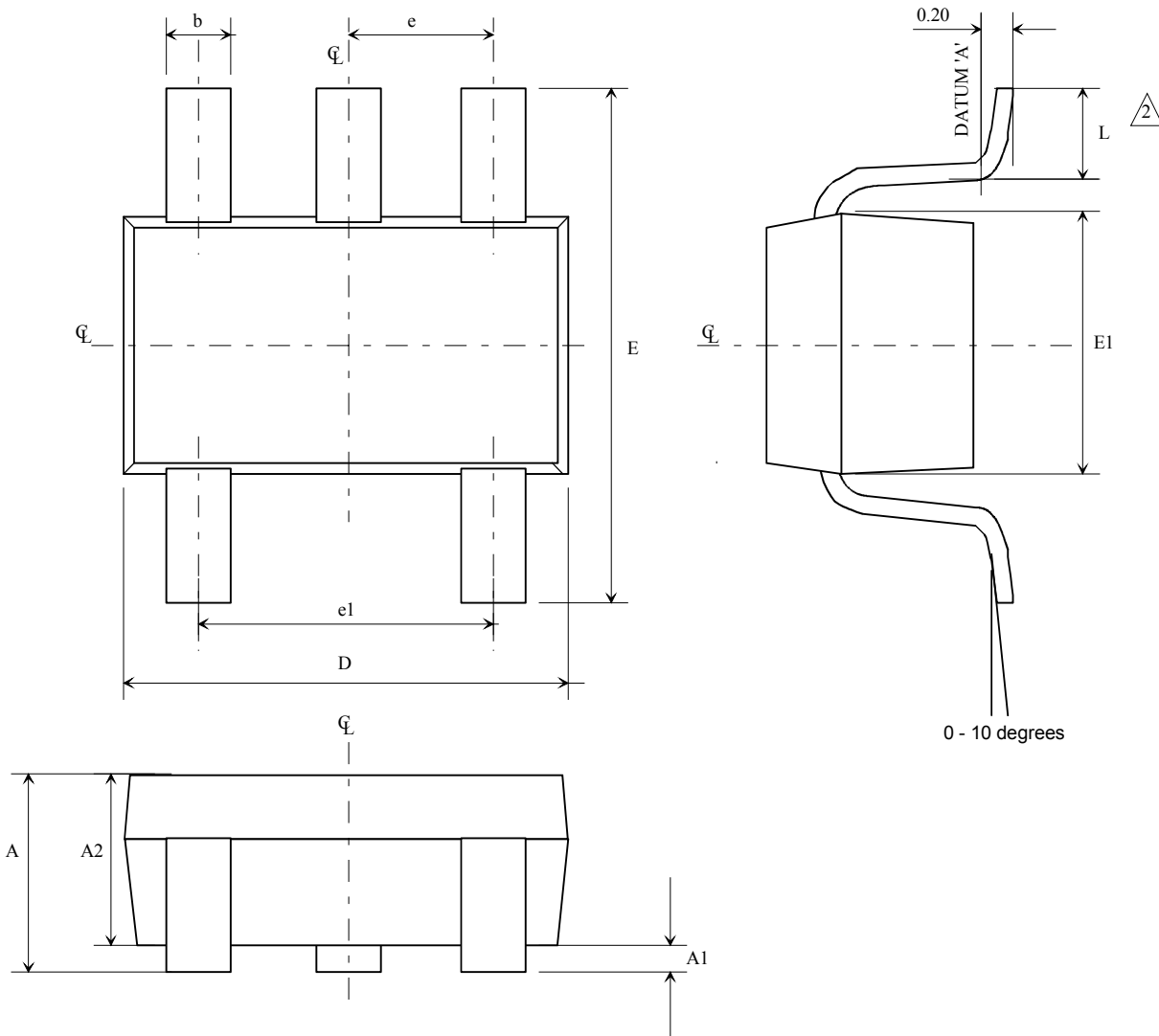

- NOTE:
1. ALL DIMENSIONS ARE IN MILLIMETERS
  2. FOOT LENGTH MEASURED AT INTERCEPT POINT BETWEEN DATUM A & LEAD SURFACE.
  3. PACKAGE OUTLINE EXCLUSIVE OF MOLD FLASH & METAL BURR
  4. PACKAGE OUTLINE INCLUSIVE OF SOLDER PLATING.
  5. COMPLY TO EIAJ SC74

Symbol	Min	Max	Unit
A	0.90	1.45	mm
A1	0.00	0.15	mm
A2	0.90	1.30	mm
b	0.25	0.50	mm
C	0.09	0.20	mm
D	2.80	3.10	mm
E	2.60	3.00	mm
E1	1.50	1.75	mm
L	0.35	0.55	mm
e	0.95ref		mm
e1	1.90ref		mm

## PACKAGE (WL-CSP) OUTLINE

All dimensions in microns, drawings not to scale.

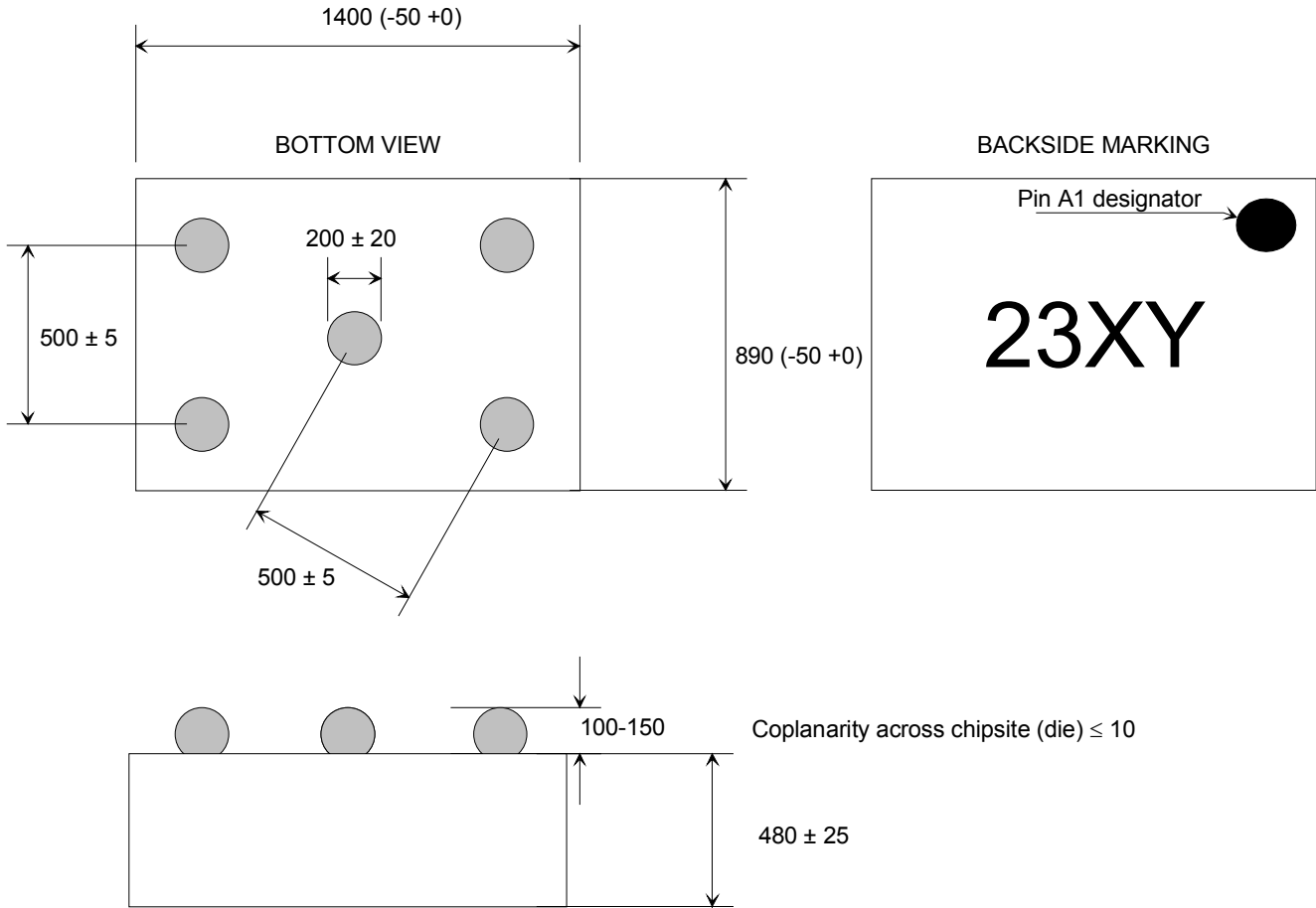

Definitions (see ordering information p. 12):

X = Package option  
Y = Output voltage option

## SOLDERING INFORMATION

Resistance to Soldering Heat	According to RSH test IEC 68-2-58/20 2*220°C
Maximum Temperature	240°C
Maximum Number of Reflow Cycles	3
Reflow profile	Thermal profile parameters stated in JESD22-A113 should not be exceeded. <a href="http://www.jedec.org">http://www.jedec.org</a>
Seating Plane Co-planarity	max 0.08 mm
Lead Finish	Solder plate 7.62 - 25.4 µm, material Sn 85% Pb 15%
WL-CSP Balls	Material Sn 63% Pb 37% (eutectic)

## TAPE & REEL SPECIFICATIONS (SOT23-5)

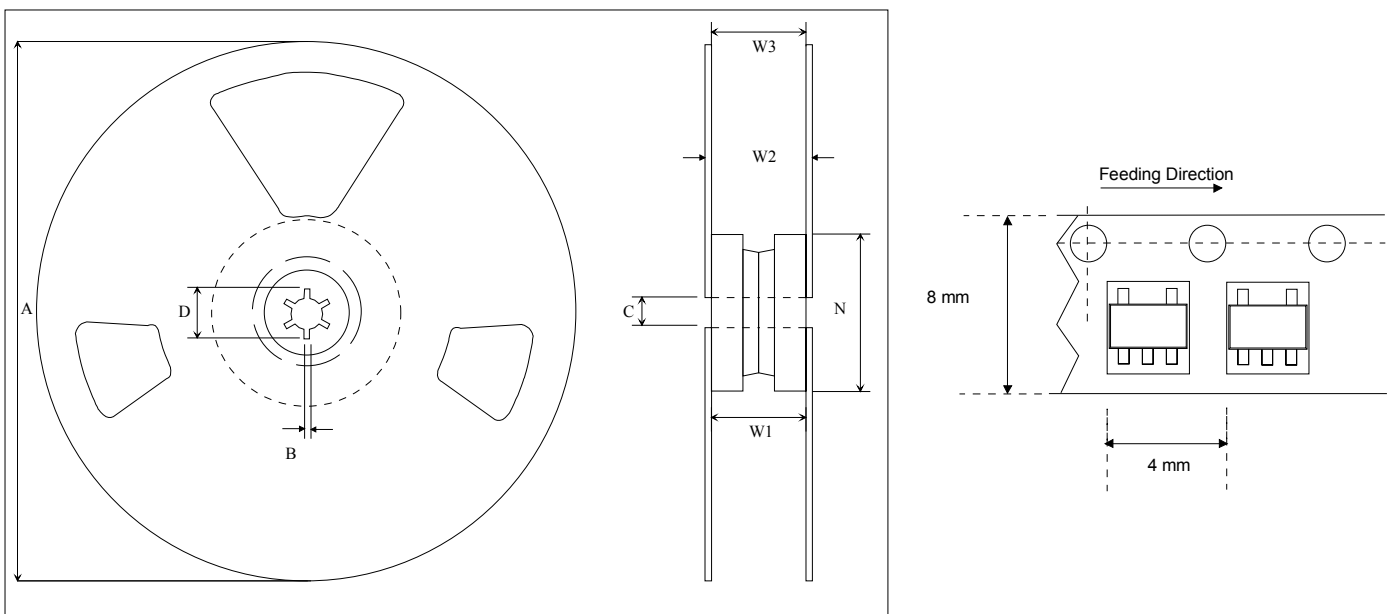

Other Dimensions according to EIA-481 Standard.

3000 Components on Each Reel.

Dimension	Min	Max	Unit
A		178	mm
B	1.5		mm
C	12.80	13.50	mm
D	20.2		mm
N	50		mm
W <sub>1</sub> (measured at hub)	8.4	9.9	mm
W <sub>2</sub> (measured at hub)		14.4	mm
Trailer	160		mm
Leader	390, of which minimum 160 mm of empty carrier tape sealed with cover tape		mm

## ORDERING INFORMATION

Product Code	Product	Top Marking	Package	Pin Order	Comments
MAS9123AST2-T	2.8 V Voltage Regulator IC	23A2	SOT23-5		Tape and Reel
MAS9123A2CA11	2.8 V Voltage Regulator IC	23A2	WL-CSP	11	Tape and Reel
MAS9123A2CA12	2.8 V Voltage Regulator IC	23Z2	WL-CSP	12	Tape and Reel
MAS9123AST6-T	3.0 V Voltage Regulator IC	23A6	SOT23-5		Tape and Reel
MAS9123A6CA11	3.0 V Voltage Regulator IC	23A6	WL-CSP	11	Tape and Reel
MAS9123A6CA12	3.0 V Voltage Regulator IC	23Z6	WL-CSP	12	Tape and Reel
MAS9123AST1-T	3.3 V Voltage Regulator IC	23A1	SOT23-5		Tape and Reel
MAS9123A1CA11	3.3 V Voltage Regulator IC	23A1	WL-CSP	11	Tape and Reel
MAS9123A1CA12	3.3 V Voltage Regulator IC	23Z2	WL-CSP	12	Tape and Reel

For more voltage options contact Micro Analog Systems Oy.

## LOCAL DISTRIBUTOR

--

## MICRO ANALOG SYSTEMS OY CONTACTS

Micro Analog Systems Oy Kamreerintie 2, P.O. Box 51 FIN-02771 Espoo, FINLAND	Tel. +358 9 80 521 Fax +358 9 805 3213 <a href="http://www.mas-oy.com">http://www.mas-oy.com</a>
--	--

### NOTICE

Micro Analog Systems Oy reserves the right to make changes to the products contained in this data sheet in order to improve the design or performance and to supply the best possible products. Micro Analog Systems Oy assumes no responsibility for the use of any circuits shown in this data sheet, conveys no license under any patent or other rights unless otherwise specified in this data sheet, and makes no claim that the circuits are free from patent infringement. Applications for any devices shown in this data sheet are for illustration only and Micro Analog Systems Oy makes no claim or warranty that such applications will be suitable for the use specified without further testing or modification.