

# KA7500B

## SMPS Controller

### Features

- Internal regulator provides a stable 5V reference supply trimmed to 5%
- Uncommitted output TR for 200mA sink or source current
- Output control for push-pull or single-ended operation
- Variable duty cycle by dead time control (pin 4) Complete PWM control circuit
- On-chip oscillator with master or slave operation
- Internal circuit prohibits double pulse at either output

### Description

The KA7500B is used for the control circuit of the PWM switching regulator. The KA7500B consists of 5V reference voltage circuit, two error amplifiers, flip flop, an output control circuit, a PWM comparator, a dead time comparator and an oscillator. This device can be operated in the switching frequency of 1 KHz to 300 KHz.

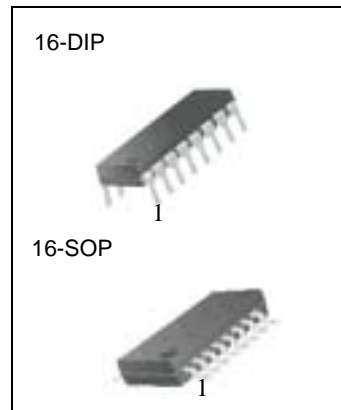

### Internal Block Diagram

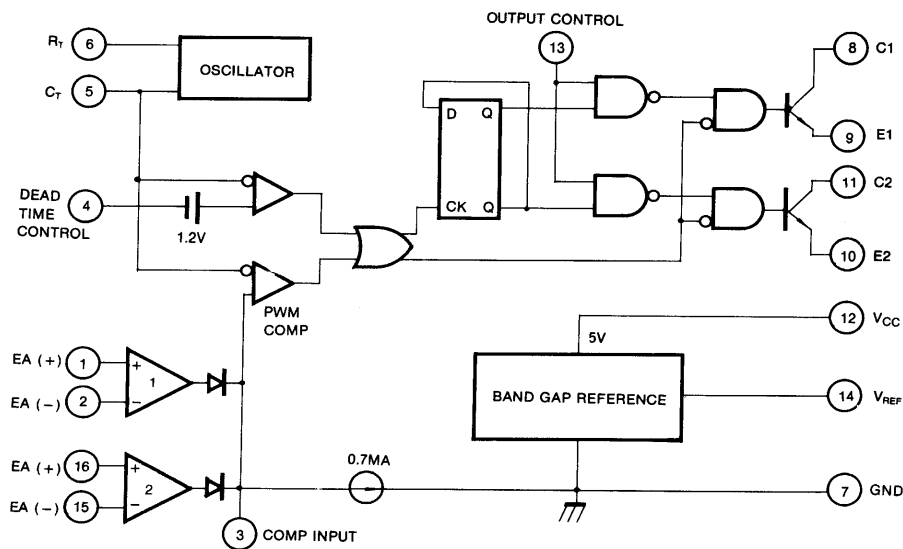

---

**Absolute Maximum Ratings**

Parameter	Symbol	Value	Unit
Supply Voltage	V <sub>CC</sub>	42	V
Collector Supply Voltage	V <sub>C</sub>	42	V
Output Current	I <sub>O</sub>	250	mA
Amplifier Input Voltage	V <sub>IN</sub>	V <sub>CC</sub> + 0.3	V
Power Dissipation (T <sub>A</sub> = 25°C)	P <sub>D</sub>	1 (KA7500B) 0.9 (KA7500BD)	W
Operating Temperature Range	T <sub>OPR</sub>	0 ~ +70	°C
Storage Temperature Range	T <sub>STG</sub>	-65 ~ + 150	°C

## Electrical Characteristics

( $V_{CC} = 20V$ ,  $f = 10KHz$ ,  $T_A = 0^{\circ}C$  to  $+70^{\circ}C$ , unless otherwise specified)

Parameter	Symbol	Conditions	Min.	Typ.	Max.	Unit
<b>REFERENCE SECTION</b>						
Reference Output Voltage	$V_{REF}$	$I_{REF} = 1mA$	4.75	5.0	5.25	V
Line Regulation	$\Delta V_{REF}$	$V_{CC} = 7V$ to $40V$	-	2.0	25	mV
Temperature Coefficient of $V_{REF}$	$\Delta V_{REF}/\Delta T$	$T_A = 0^{\circ}C$ to $70^{\circ}C$	-	0.01	0.03	%/ $^{\circ}C$
Load Regulation	$\Delta V_{REF}$	$I_{REF} = 1mA$ to $10mA$	-	1.0	15	mV
Short-Circuit Output Current	$I_{SC}$	$V_{REF} = 0V$	10	35	50	mA
<b>OSCILLATOR SECTION</b>						
Oscillation Frequency	f	$C_T = 0.01\mu F$ , $R_T = 12K\Omega$	-	10	-	KHz
Frequency Change with Temperature	$\Delta f/\Delta T$	$C_T = 0.01\mu F$ , $R_T = 12K\Omega$	-	-	2	%
<b>DEAD TIME CONTROL SECTION</b>						
Input Bias Current	$I_{BIAS}$	$V_{CC} = 15V$ , $0V \leq V_4 \leq 5.25V$	-	-2.0	-10	$\mu A$
Maximum Duty Cycle	$D_{(MAX)}$	$V_{CC} = 15V$ , $V_4 = 0V$ O.C Pin = $V_{REF}$	45	-	-	%
Input Threshold Voltage	$V_{ITH}$	Zero Duty Cycle	-	3.0	3.3	V
		Max. Duty Cycle	0	-	-	
<b>ERROR AMP SECTION</b>						
Input Offset Voltage	$V_{IO}$	$V_3 = 2.5V$	-	2.0	10	mV
Input Offset Current	$I_{IO}$	$V_3 = 2.5V$	-	25	250	mA
Input Bias Current	$I_{BIAS}$	$V_3 = 2.5V$	-	0.2	1.0	$\mu A$
Common Mode Input Voltage	$V_{CM}$	$7V \leq V_{CC} \leq 40V$	-0.3	-	$V_{CC}$	V
Open-Loop Voltage Gain	$G_{VO}$	$0.5V \leq V_3 \leq 3.5V$	70	95	-	dB
Unit-Gain Bandwidth	BW	-	-	650	-	KHz
<b>PWM COMPARATOR SECTION</b>						
Input Threshold Voltage	$V_{ITH}$	Zero Duty Cycle	-	4	4.5	V
Input Sink Current	$I_{SINK}$	$V_3 = 0.7V$	-0.3	-0.7	-	mV
<b>OUTPUT SECTION</b>						
Output Saturation Voltage Common Emitter	$V_{CE(SAT)}$	$V_E = 0$ , $I_C = 200mA$	-	1.1	1.3	V
	$V_{CC(SAT)}$	$V_C = 15V$ , $I_E = -200mA$	-	1.5	2.5	
Collector Off-State Current	$I_{C(OFF)}$	$V_{CC} = 40V$ , $V_{CE} = 40V$	-	2	100	$\mu A$
Emitter Off-State Current	$I_{E(OFF)}$	$V_{CC} = V_C = 40V$ , $V_E = 0$	-	-	-100	
<b>TOTAL DEVICE</b>						
Supply Current	$I_{CC}$	Pin 6 = $V_{REF}$ , $V_{CC} = 15V$	-	6	10	mA
<b>OUTPUT SWITCHING CHARACTERISTIC</b>						
Rise Time	$t_R$	-	-	-	-	-
Common Emitter	-	-	-	100	200	ns
Common Collector	-	-	-	100	200	
Fall Time	$t_F$	-	-	-	-	-
Common Emitter	-	-	-	25	100	ns
Common Collector	-	-	-	40	100	

# Typical Application

## Pulse Width Modulated Step-down Converter

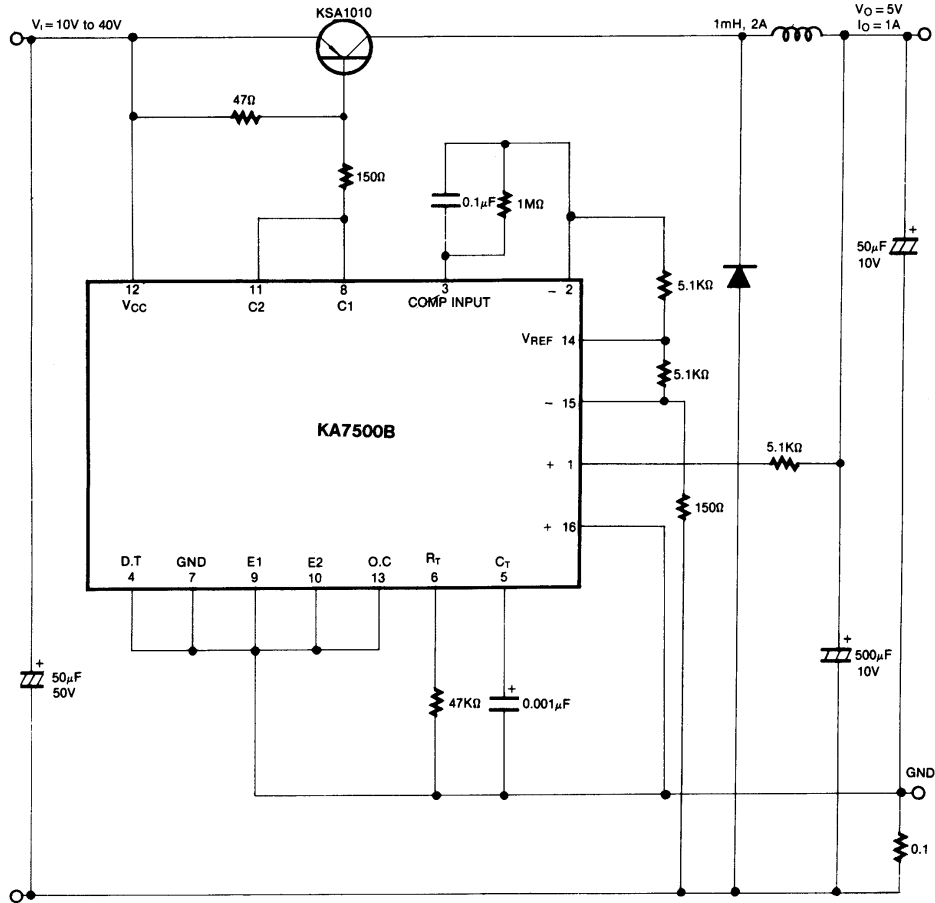

# Mechanical Dimensions

## Package

### 16-DIP

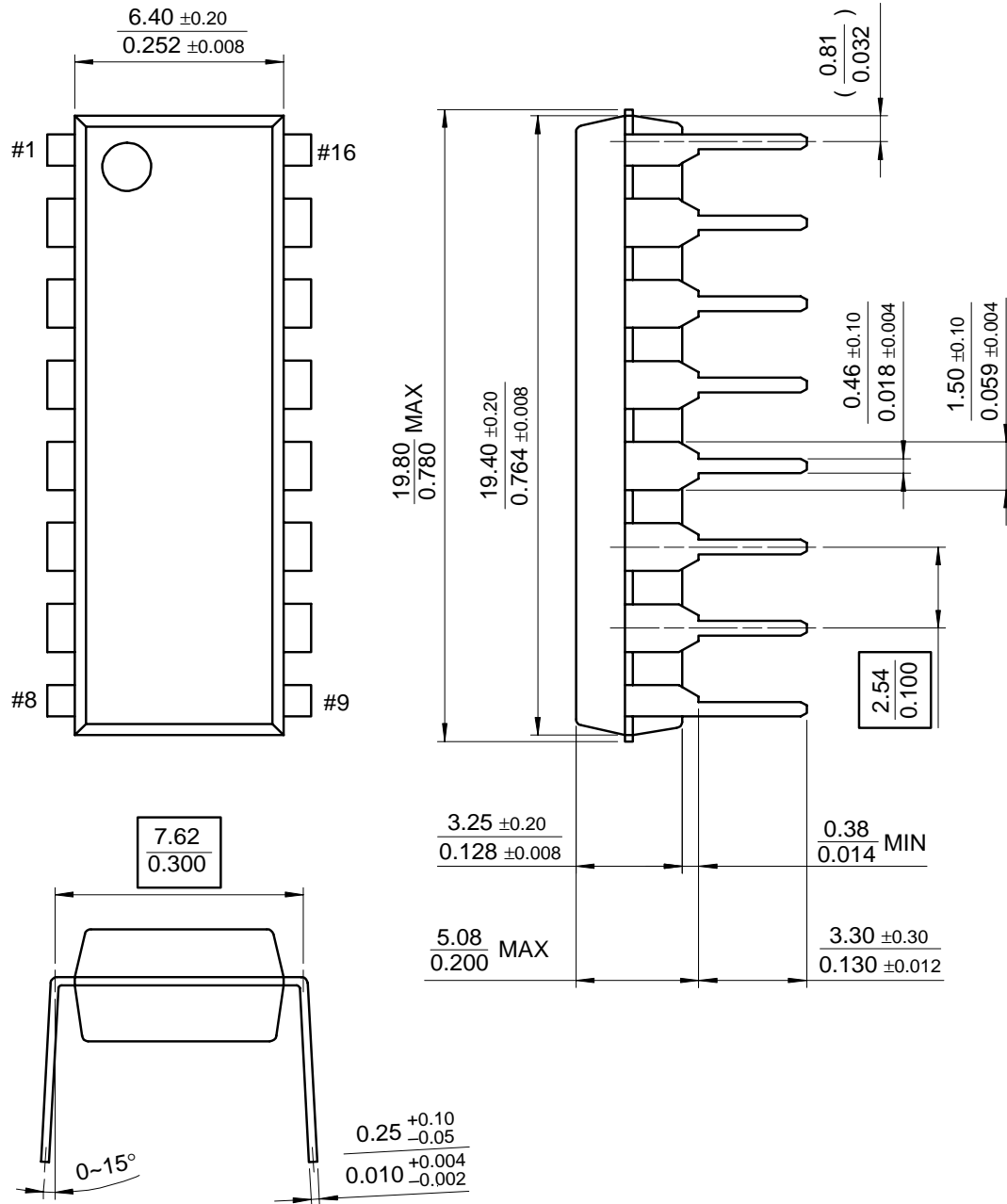

# Mechanical Dimensions (Continued)

## Package

### 16-SOP

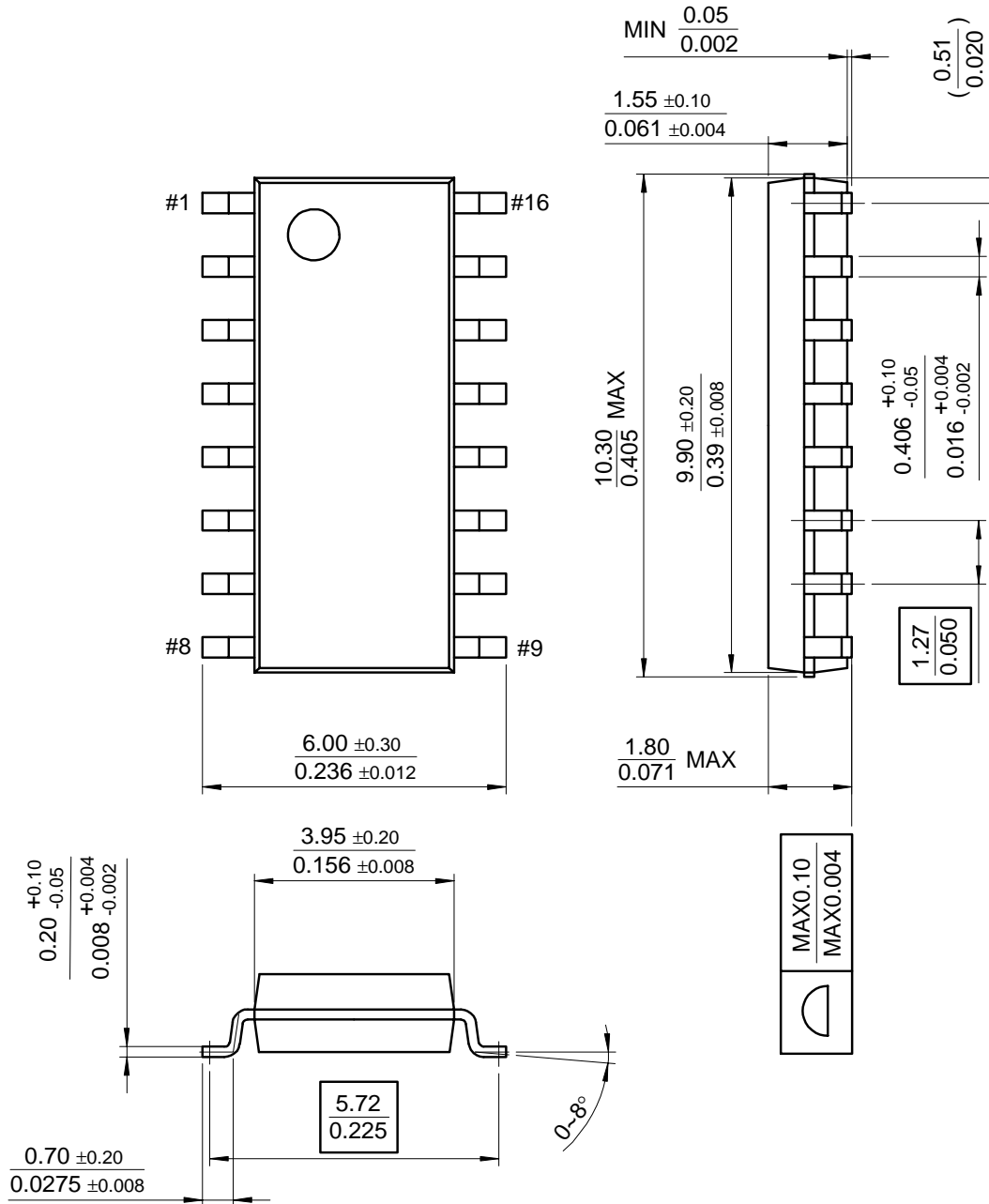

**Ordering Information**

<b>Product Number</b>	<b>Package</b>	<b>Operating Temperature</b>
KA7500B	16 DIP	0 ~ + 70°C
KA7500BD	16 SOP	