

C503 LINEAR HALLEFFECT Sensors

C503 linear Hall-effect integrated circuit includes a voltage regulator, Hall-voltage generator, linear amplifier, and emitter-follower output stage. The output of the ICs changes linearly with the magnetic flux density of the input.



FEATURES

- Small Size
- High Accuracy
- High Sensitivity
- Excellent Reliability
- High Linearity

TYPICAL APPLICATION

- Motion Detector
- Gear Tooth Sensors
- Proximity Detector
- Current Detecting Sensor
- Velocity Detecting of Motor Bicycle

ABSOLUTE MAXIMUM RATINGS

Parameter	Symbol	Value	Unit
Supply Voltage	V _{CC}	8	V
Operating Temperature Range	T _A	-20~+85	°C
Storage Temperature Range	T _S	-65~+150	°C

FUNCTIONAL BLOCK DIAGRAM

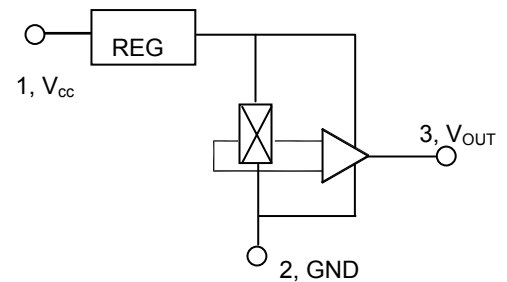

ELECTRICAL CHARACTERISTICS (T_A=25°C, V_{CC}=5.0V)

TYPE	Supply current I _{CC} (mA)			Quiescent Output Voltage V _O (V)			Sensitivity S (mV/mT)			Output upper Limit Voltage V _T (V) _B ≥200mT			Output Lower Limit Voltage V _L (V) _B ≤-200mT			Output function
	Min	Typ	Max	Min	Typ	Max	Min	Typ	Max	Min	Typ	Max	Min	Typ	Max	
C503	-	9.0	14.0	2.25	2.50	2.75	7.5		25.0	4.20	4.25	4.30	0.75	1.00	1.20	Linear

Package Outline Drawing (Unit: mm)

- TO-92UA Package and Position of Sensitive Area
- TO-92T Package and Position of Sensitive Area
- TO-92U Package and Position of Sensitive Area

Pin Notes: (TO-92UA, TO-92T, TO-92U Package)

1. Power Supply
2. Ground
3. Output

Connection

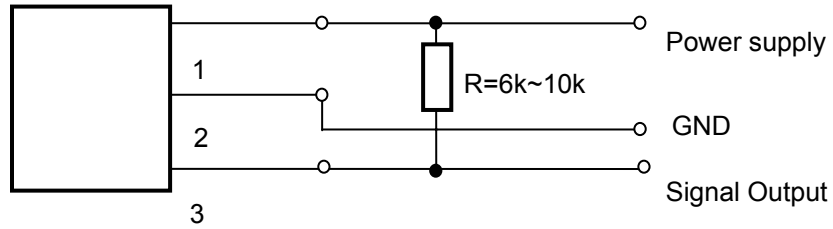

Characteristics Curves

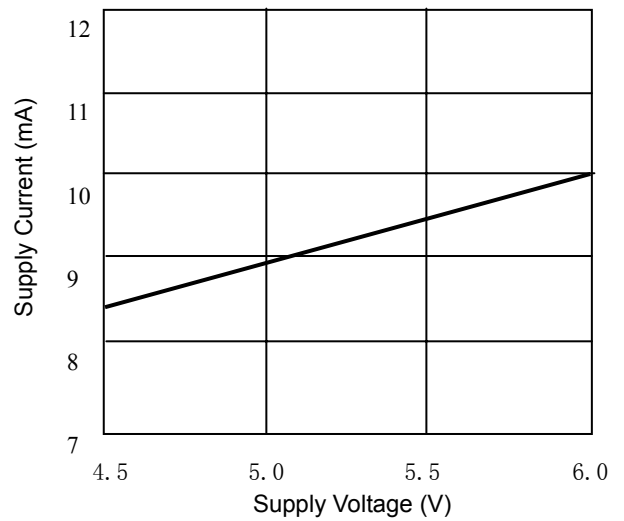
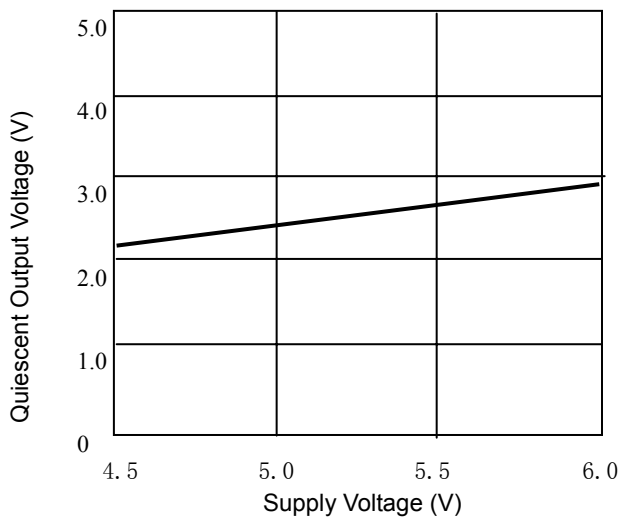
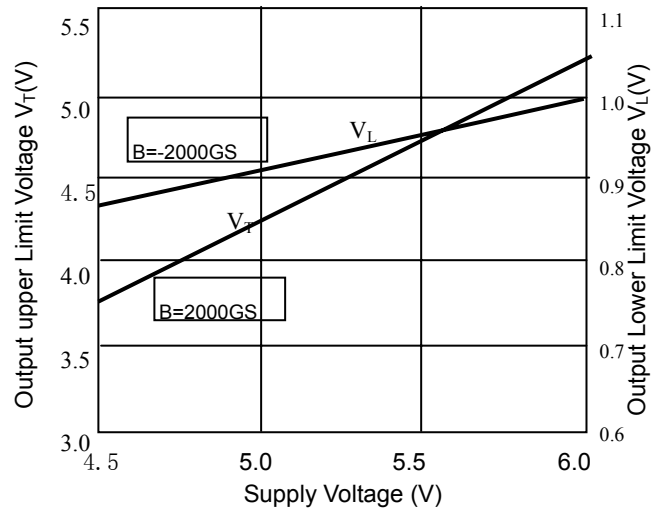
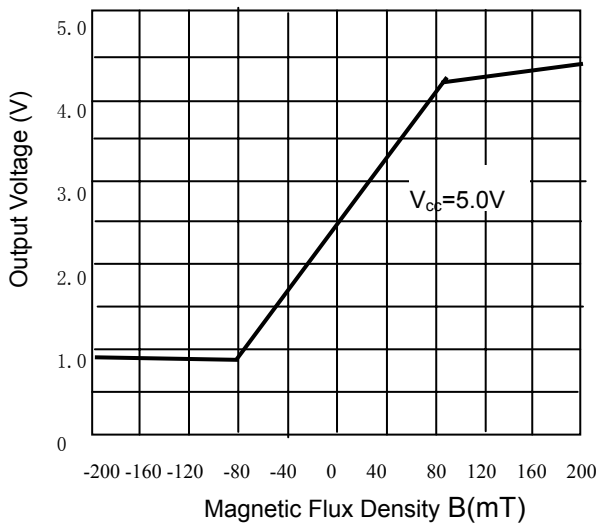

Principles

The quiescent output voltage ($B=0\text{mT}$) is nominally one-half the supply voltage. When a south magnetic pole presented to the branded face of the Hall-effect IC, it will drive the output higher than the quiescent voltage. A north magnetic pole will drive the output below the quiescent output voltage. In operation, instantaneous and proportional output voltage levels are dependent on magnetic flux density at the most sensitive area of the device. Greatest sensitivity is obtained with a supply voltage of 6V, but at the cost of increased supply current and a slight loss of output symmetry. The IC' output is usually capacitively coupled to an amplifier that boosts the output above the millivolt level.

Applications

NOTCH SENSOR

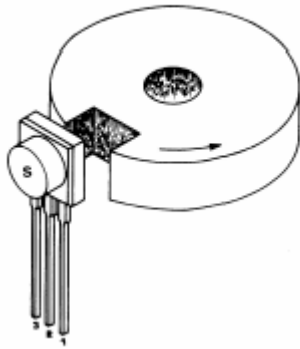

GEAR TOOTH SENSOR

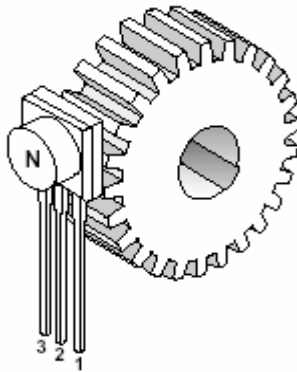

CURRENT MONITOR

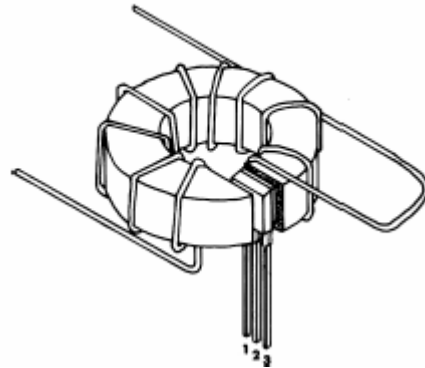

Note:

Mechanical stress should be lessened as far as possible in the process of assembly.

The soldering temperature at the leads should be less than 260°C with 5 seconds. If N pole is approaching Hall-effect ICs from the back side of the package, output voltage will increase, S pole is approaching ICs from the back side, output voltage will reduce; and if from the branded side of the package, the output situation is just to the contrary.
