

Etulevy

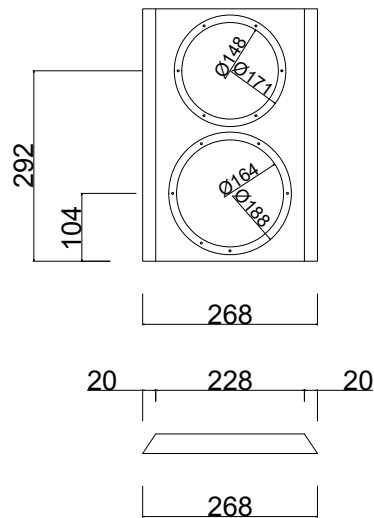

Takalevy

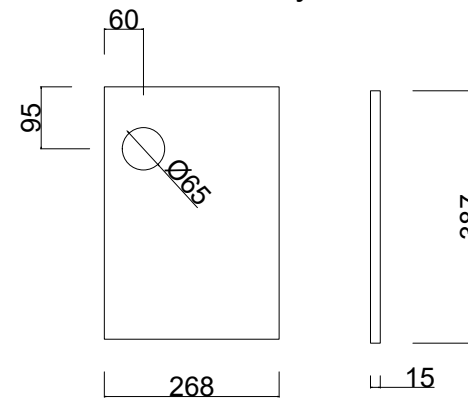

Kyljet x 2



Katto & pohja x 2

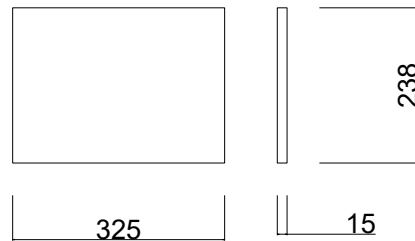

Sisätuet

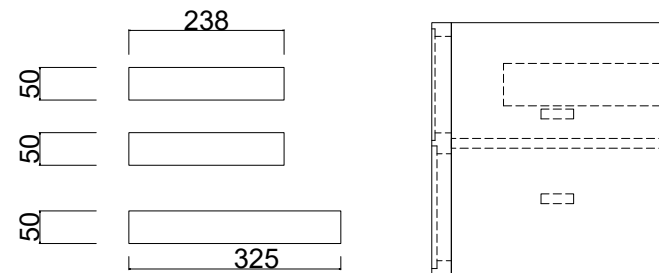

MATERIAL		15 mm vaneri		GENTOL		ISO	
SURFACE TREATMENT		none		PART NUMBER			
CREATOR	DESCRIPTION	CAD DRAWING BY:		REVISION			
19.12.2023 J.A.	Uraltone Ref 2	kuviopuu.fi		1.0			
DESIGN BY:	Samu Saurama	SCALE	1:1	SHEET	1/3	A4	

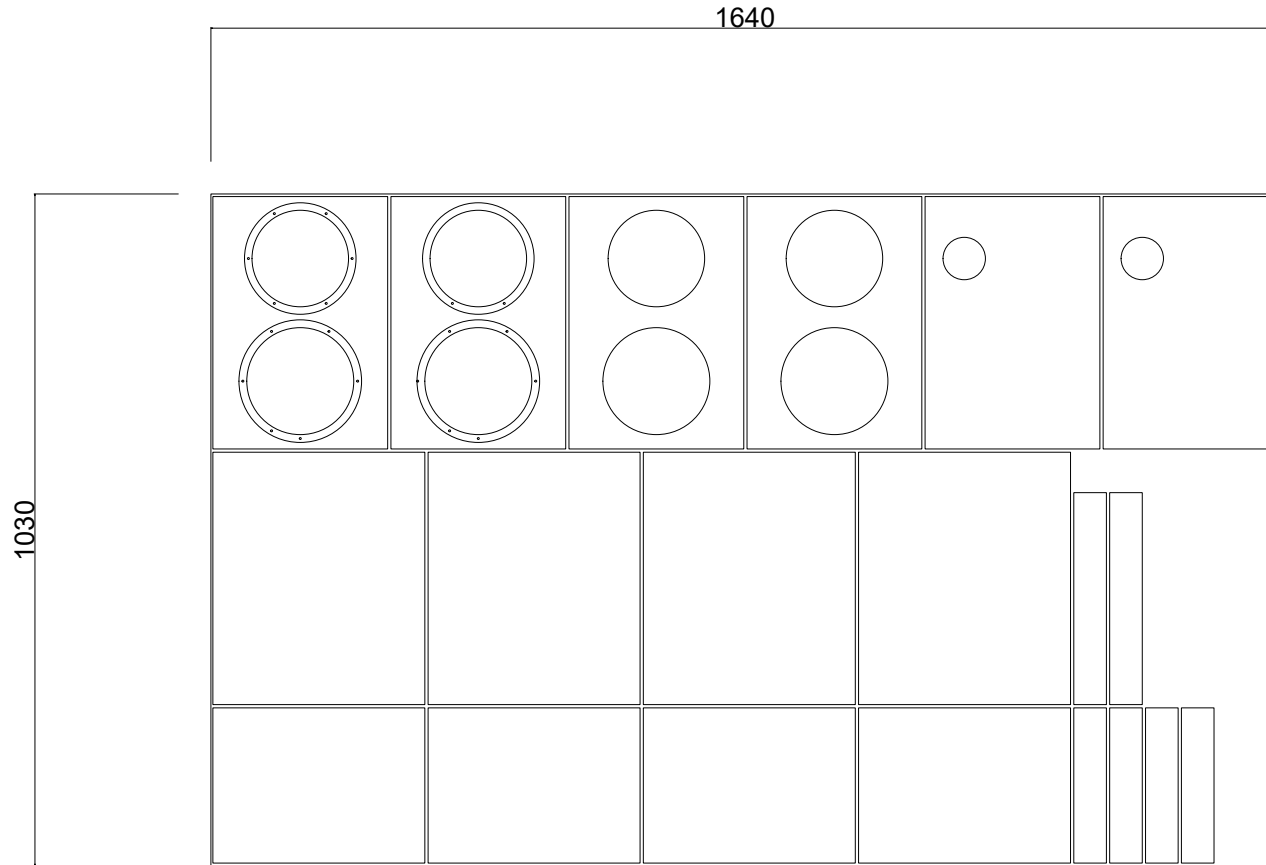

Osalista: (2 koteloa - levyaiho 15 x 1030 x 1640 mm)

1.	Etulevy	15 x 268 x 387 mm	2 kpl
2.	Etulevy tuplaus	15 x 268 x 387 mm	2 kpl
3.	Kyljet	15 x 325 x 387 mm	4 kpl
4.	Pohja / katto	15 x 325 x 238 mm	4 kpl
5.	Takalevy	15 x 268 x 387 mm	2 kpl
6.	Sisätuki (etu-taka)	15 x 325 x 238 mm	2 kpl
7.	Sisätuki (kylki-kylki)	15 x 268 x 387 mm	4 kpl

MATERIAL		15 mm vaneri		GENTOL		ISO	
SURFACE TREATMENT		none		PART NUMBER			
CREATOR	19.12.2023 J.A.	DESCRIPTION	Uraltone Ref 2		CAD DRAWING BY:	kuviopuu.fi	
DESIGN BY:	Samu Saurama	SCALE	1:1	SHEET	2/3	REVISION	
						1.0	
						A4	

7.5" SATORI MW19TX-8

Prototype Data

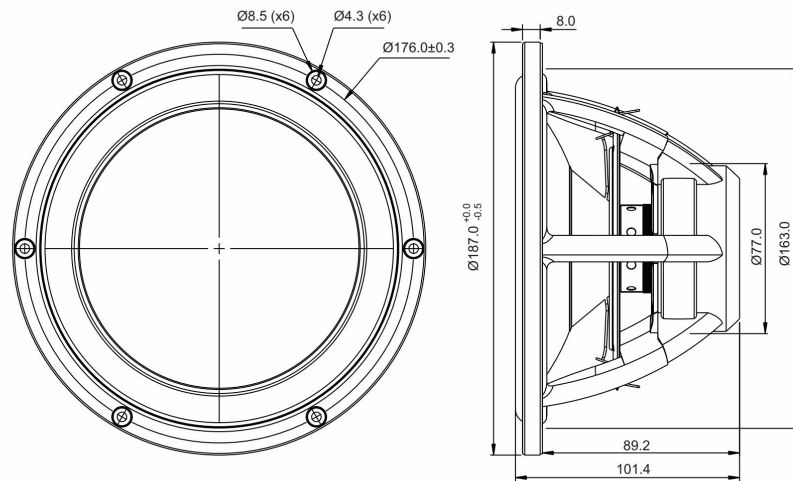

TW29BNWG-8

Preliminary Data

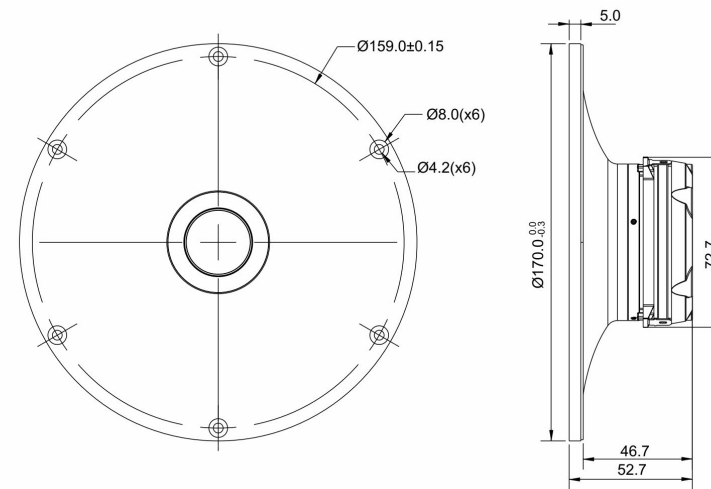

MATERIAL		15 mm vaneri		GEN.TOL.		ISO	
SURFACE TREATMENT		none		PART NUMBER			
CREATOR	DESCRIPTION	CAD DRAWING BY:		REVISION			
19.12.2023 J.A.	Uraltone Ref 2	kuviopuu.fi		1.0			
	DESIGN BY:	SCALE	SHEET				
	Samu Saurama	1:1	3/3			A4	