 <p>1X503</p>	<p>Features:</p> <ul style="list-style-type: none"> • 1.7 - 2.0 GHz • Very Low Loss • High Isolation • 90° Quadrature • Surface Mountable • Tape And Reel • Convenient Package • 100% Tested 	<p>Description:</p> <p>The 1X503 is a low profile, miniature 3dB hybrid coupler in an easy to use surface mount package designed for DCS and PCS applications. The 1X503 is designed for balanced amplifiers and signal distribution and is an ideal solution for the ever increasing demands of the wireless industry for smaller printed circuit boards. Parts have been run through rigorous qualification testing and units are 100% tested. They are manufactured using materials with x and y thermal expansion coefficients compatible with common substrates such as FR4, G-10 and polyamide.</p>
---	---	--

MECHANICAL OUTLINE:

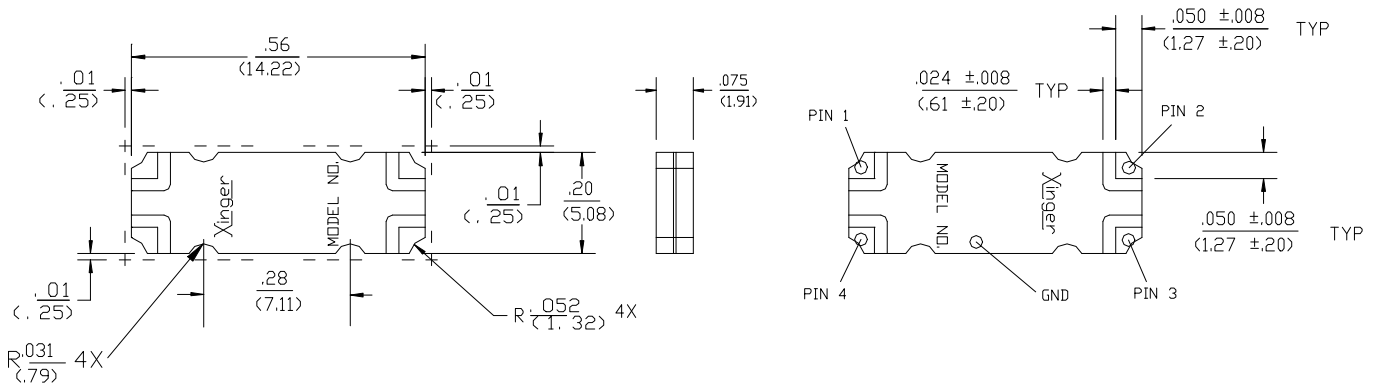

ELECTRICAL SPECIFICATIONS:

	1X503	
Specification	Bandwidth	Units
Frequency	1.7 - 2.0	GHz
Isolation	23	dB min.
Insertion Loss	0.20	dB max.
VSWR	1.17	Max:1
Amplitude Balance	±0.20	dB max.
Phase Balance	2	Degrees max.
Power Handling	60	Avg. Watts - CW max.
ΘJC	20.6	Deg.C/Watt

Specifications based on performance of units installed in an RF test fixture. 50 ohms nominal impedance. -55°C to +85°C operating temperature. Unit will operate to +125°C with minor degradation in Insertion Loss performance. Specifications subject to change without notice.



TYPICAL PERFORMANCE: (@ 25°C in test fixture)

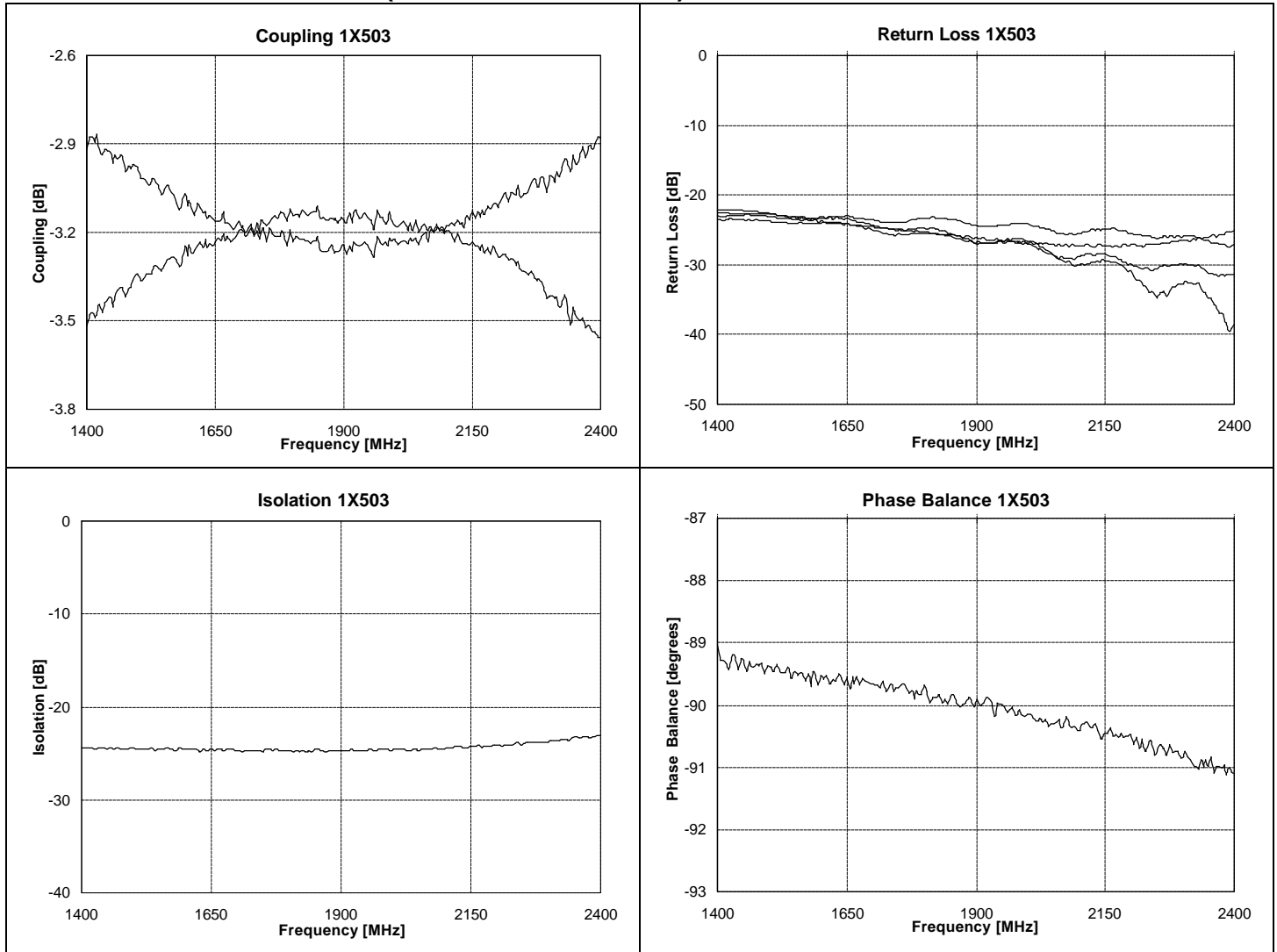

AMPLITUDE BALANCE

3dB hybrids are a type of backward wave coupler. In the design of these couplers, the even mode impedance was chosen to 'critically couple' or slightly 'over couple' at mid band to maximize performance and bandwidth. The amplitude balance specification is defined as the decibel difference between the two output curves.

PHASE BALANCE

In theory, output ports of a backward wave hybrid coupler remain in perfect phase quadrature independent of frequency. In practice, factors associated with the manufacturing processes slightly degrade performance. The specification is typical two to three degrees maximum although in practice, phase balance is statistically better than specified (1°).

VSWR & ISOLATION

Similar to phase balance, the VSWR and isolation of a coupler are theoretically perfect; where the input and output ports are perfectly matched and no power is coupled to the isolated port. In practice, factors associated with the design and manufacturing processes limit VSWR and isolation. The significant limitations are associated with the internal meandered circuit traces as well as limitations of building perfect 50Ω transitions at the input and output ports of the device. Typically, VSWR and isolation of 1.15:1 and 25 dB respectively are achieved in practice.

INSERTION LOSS

Coupler insertion loss is defined as the difference of the input power from the sum of the output power. In



practice, loss is typically 0.15 dB. Specification limits are somewhat higher due to imperfect test conditions; as the couplers must be tested in fixtures which negatively effect results.

PIN CONFIGURATION

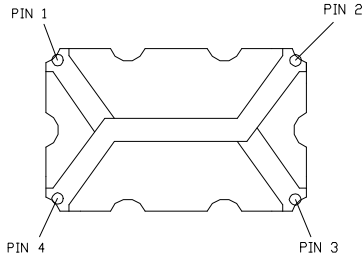

Surface Mount 3dB Coupler Layout

All of the standard surface mount 3dB hybrid couplers have pin orientations which are symmetrical. When a port is designated as the input, automatically the two output and isolated ports are defined. For example, if the input port for a device was selected to be Pin 1, Pin 2 is automatically the isolated port, Pin 4 is the 0 degree reference output port, and Pin 3 is the output port which "lags" behind the reference output port by 90 degrees. Similarly, if Pin 3 was to be selected as the input port, the adjacent port on the long side (Pin 4) is the isolated port, the adjacent port on the short side (Pin 2) is the 0 degree output port, and the opposite port (Pin 1) is the -90 degree output port. Below is a table of all possible orientations.

	Pin 1	Pin 2	Pin 3	Pin 4
#1	Input	Isolated	-3dB, -90°	-3dB, 0°
#2	Isolated	Input	-3dB, 0°	-3dB, -90°
#3	-3dB, -90°	-3dB, 0°	Input	Isolated
#4	-3dB, 0°	-3dB, -90°	Isolated	Input

Pin Configurations

MOUNTING

In order for Xinger surface mount couplers to work optimally, there must be 50Ω transmission lines leading to and from all of the RF ports. Also, there must be a very good ground plane under the part to insure proper electrical performance. If either of these two conditions

are not satisfied, insertion loss, coupling, VSWR and directivity may not meet published specifications.

Overall ground is improved if a dense population of plated through holes connect the top and bottom ground layers of the PCB. This minimizes ground inductance and improves ground continuity. Performance can also be improved when grounded coplanar waveguide is used as the transmission medium and a low loss dielectric is used. All of the Xinger hybrid and directional couplers are constructed from ceramic filled PTFE composites which possess excellent electrical and mechanical stability having X and Y thermal coefficient of expansion (CTE) of 17 ppm/°C

When a surface mount hybrid coupler is mounted to a printed circuit board, the primary concerns are; insuring the RF pads of the device are in contact with the circuit trace of the PCB and insuring the ground plane of neither the component nor the PCB is in contact with the RF signal. As long as the geometry of the unit fits onto the layout of the circuit trace on the PCB, and the conditions of the previous paragraph are followed, the coupler's performance is ensured. An example of how the PCB footprint could look is shown below. In specific designs, the 50Ω lines need to be adjusted to the unique dielectric coefficients and thicknesses as well as varying pick and place equipment tolerances.

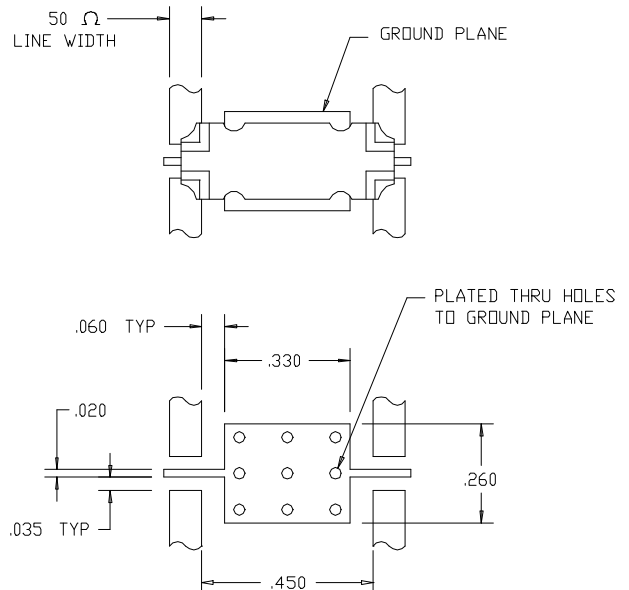

SUGGESTED FOOTPRINT

