

---

---

**3-CHANNEL WHITE LED DRIVER IC  
(CHARGE PUMP IC WITH A BUILT-IN  
CONSTANT-CURRENT CIRCUIT)**

---

---

**S-8813 Series**

The S-8813 Series is a PFM control charge pump DC-DC converter with a built-in constant-current circuit, and was developed using CMOS technology. Its constant current output makes this series ideal as a power supply for current drive LEDs.

The S-8813 Series features three output channels and can drive three LEDs.

This series is available in two types: a variable voltage type and a variable current setting resistance type.

Moreover, since small ceramic capacitors can be used as external capacitors (pump capacitors, input capacitors, output capacitors), the S-8813 Series contributes to set miniaturization.

**■ Features**

- PFM control CMOS charge pump
- Built-in constant-current circuit
- Power supply voltage: 2.7 V to 4.5 V
- Output current value: A current variable is possible between 5.0 mA and 18 mA  
(At  $V_{IOUT1,2,3} \leq 4.0$  V,  $V_{IN} = 3.0$  V)  
Variable voltage type and Variable current setting resistance type are available.
- Terminal output current matching:  $\pm 1\%$  max.
- Built-in soft start circuit: 1.5 ms typ.
- Constant current output pins: 3 channels,  $\pm 5\%$  accuracy
- Oscillation frequency: 600 kHz typ.
- ON/OFF function provided (During standby: 1  $\mu$ A max.)
- Ultra-small package: 10-Pin SON(B)

**■ Applications**

- Power supply for white LED display backlights
- Constant-current circuit
- Cellular phones and PDAs using 1-cell lithium batteries
- Power supply for flat panel displays

**■ Package**

- 10-Pin SON(B) (Package drawing code: PE010-A)

**■ Part Numbers**

- S-881300CPE-IPA-TF (Variable current setting resistance type)
- S-881300BPE-IOQ-TF (Variable voltage type)

■ **Block Diagram**

**1. S-881300CPE**

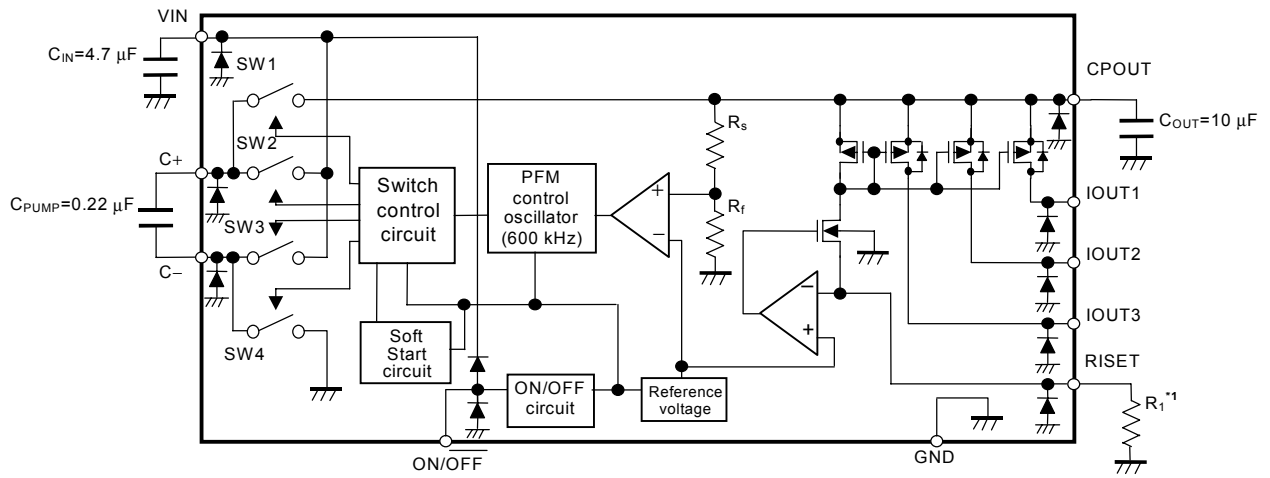

**2. S-881300BPE**

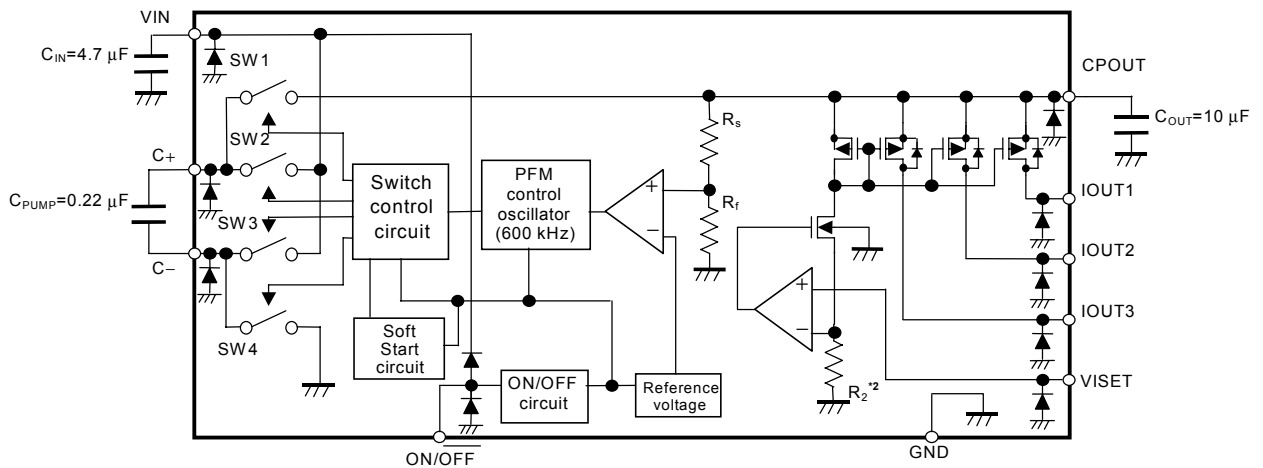

\*1. Current setting resistance

\*2. Internal resistance

**Figure 1 Block Diagram**

# 3-CHANNEL WHITE LED DRIVER IC (CHARGE PUMP IC WITH A BUILT-IN CONSTANT-CURRENT CIRCUIT)

Rev.1.1\_10

S-8813 Series

## ■ Pin Assignment

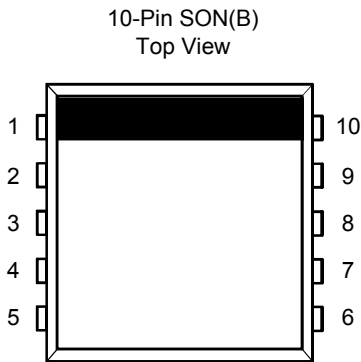

**Figure 2 Pin Assignment**

**Table 1 Pin Descriptions**

Pin No.	Pin Name	Function
1	IOUT1	Output pin (constant-current output)
2	IOUT2	Output pin (constant-current output)
3	IOUT3	Output pin (constant-current output)
4	C+	Pump capacitor connection pin (positive pin)
5	C-	Pump capacitor connection pin (negative pin)
6	GND	GND pin
7	VIN	Voltage input pin
8	CPOUT	Charge pump output pin (capacitor connection pin)
9	RISET / VISET	Variable output current pins In the case of RISET, a resistor is connected to this pin and changing the resistance value can vary the output current. In the case of VISET, changing the voltage applied to this pin can vary the output current.
10	ON/OFF	Power-off pin High level: Normal operation (Step-up operation) Low level: Stepping-up halt (Whole circuit stopped)

## ■ Absolute Maximum Ratings

**Table 2 Absolute Maximum Ratings**

(Unless otherwise specified, Ta = 25°C)

Parameter	Symbol	Absolute Maximum Rating	Unit
IOUT 1, 2, 3 pin voltage	V <sub>IOUT1,2,3</sub>	V <sub>SS</sub> -0.3 to V <sub>SS</sub> +7	V
C+ pin voltage	V <sub>C+</sub>	V <sub>SS</sub> -0.3 to V <sub>SS</sub> +7.5	V
C- pin voltage	V <sub>C-</sub>	V <sub>SS</sub> -0.3 to V <sub>SS</sub> +7	V
VIN pin voltage	V <sub>IN</sub>	V <sub>SS</sub> -0.3 to V <sub>SS</sub> +5	V
CPOUT pin voltage	V <sub>CPOUT</sub>	V <sub>SS</sub> -0.3 to V <sub>SS</sub> +7	V
RISET/VISET pin voltage	V <sub>RISET</sub> /V <sub>VISET</sub>	V <sub>SS</sub> -0.3 to V <sub>SS</sub> +7	V
ON/OFF pin voltage	V <sub>ON/OFF</sub>	V <sub>SS</sub> -0.3 to V <sub>IN</sub> +0.3	V
Operating temperature range	T <sub>opr</sub>	-40 to +85	°C
Storage temperature range	T <sub>stg</sub>	-40 to +125	°C
Power dissipation	P <sub>D</sub>	290	mW

**Caution** The absolute maximum ratings are rated values exceeding which the product could suffer physical damage. These values must therefore not be exceeded under any conditions.

■ **Electrical Characteristics**

**1. S-881300CPE**

**Table 3 Electrical Characteristics**

(Unless otherwise specified,  $V_{IN} = 3.0\text{ V}$ , current setting resistance = 5.6 k $\Omega$ ,  $T_a = 25^\circ\text{C}$ )

Item	Symbol	Conditions	Min.	Typ.	Max.	Unit	Test Circuit
Operation input voltage	$V_{IN}$	—	2.7	—	4.5	V	2
Stabilized output current	$I_{OUT}$	$V_{IN} = 3.0\text{ V to }4.5\text{ V}$ $V_{IOUT1,2,3}^{*1} \leq 3.6\text{ V}$	23	—	—	mA	
		$V_{IN} = 3.0\text{ V to }4.5\text{ V}$ $V_{IOUT1,2,3}^{*1} \leq 4.0\text{ V}$	18	—	—		
		$V_{IN} = 2.7\text{ V to }3.0\text{ V}$ $V_{IOUT1,2,3}^{*1} \leq 3.6\text{ V}$	14	—	—		
Output current $V_{IOUT}$ characteristics	$\Delta I_{OUT1}$	$V_{IN} = 3.0\text{ V}$ , $V_{IOUT} = 3.0\text{ V to }4.0\text{ V}$	—	0.5	1		
Output current input stability	$\Delta I_{OUT2}$	$V_{IN} = 3.0\text{ V to }4.5\text{ V}$ $V_{IOUT} \leq 3.6\text{ V}$	—	0.5	1		
Output current accuracy	$\frac{\Delta I_{OUT1}}{I_{OUT}}$	$I_{OUT1,2,3} = 17.8\text{ mA}$	-5.0	—	+5.0	%	
Inter-pin output current variation	$\Delta I_M$	$V_{IOUT} = 3.6\text{ V}$	-1.0	—	+1.0		
Ripple voltage	$V_{RIP}$	$V_{IN} = 2.7\text{ V to }4.5\text{ V}$ $I_{OUT1,2,3} = 18\text{ mA}$	—	—	100	mV <sub>p-p</sub>	
Maximum oscillation frequency	$f_{osc}$	$V_{CP\text{OUT}} = 4.75\text{ V}$ Measure waveform at C- pin	540	600	660	kHz	1
Efficiency <sup>*2</sup>	$\eta$	$V_{IN} = 3.0\text{ V}$ , $I_{OUT1,2,3} = 18\text{ mA}$	—	82	—	%	2
Operation consumption current	$I_{SS1}$	$V_{IN} = 2.7\text{ V to }4.5\text{ V}$ $V_{CP\text{OUT}} = 4.75\text{ V}$	—	1	1.5	mA	
Standby consumption current	$I_{SSS}$	$V_{IN} = 2.7\text{ V to }4.5\text{ V}$	—	0.3	1	$\mu\text{A}$	
Power-off pin input voltage (high level)	$V_{SH}$	$V_{IN} = 2.7\text{ V to }4.5\text{ V}$	2.0	—	—	V	
Power-off pin input voltage (low level)	$V_{SL}$	$V_{IN} = 2.7\text{ V to }4.5\text{ V}$	—	—	0.3		
Power-off pin input current (high level)	$I_{SH}$	$V_{IN} = 2.7\text{ V to }4.5\text{ V}$	-0.1	—	0.1	$\mu\text{A}$	
Power-off pin input current (low level)	$I_{SL}$	$V_{IN} = 2.7\text{ V to }4.5\text{ V}$	-0.1	—	0.1		
Soft start time	$t_{SS}$	$V_{IN} = 2.7\text{ V to }4.5\text{ V}$	0.3	1.5	3	ms	2
RISET pin voltage	$V_{RISET}$	$V_{IN} = 2.7\text{ V to }4.5\text{ V}$	0.98	1	1.02	V	

\*1.  $V_{IOUT1,2,3}$  are the voltages of the IOUT pin.

\*2. "Efficiency" in the electrical characteristics means the efficiency of the charge pump circuit block. The ideal efficiency is indicated by the following expression.

$$\text{Efficiency} = [V_{CP\text{OUT}} \times (I_{OUT1} + I_{OUT2} + I_{OUT3})] / [2.0 \times V_{IN} \times (I_{OUT1} + I_{OUT2} + I_{OUT3})]$$

The ideal efficiency including the constant current circuit is expressed as following expression.

$$\text{Efficiency} = [(V_{IOUT1} \times I_{OUT1}) + (V_{IOUT2} \times I_{OUT2}) + (V_{IOUT3} \times I_{OUT3})] / [2.0 \times V_{IN} \times (I_{OUT1} + I_{OUT2} + I_{OUT3})]$$

**Remark** The numbers in the "test circuit" column correspond to the circuit numbers in the "**Measurement Circuits**" section.

**3-CHANNEL WHITE LED DRIVER IC  
(CHARGE PUMP IC WITH A BUILT-IN CONSTANT-CURRENT CIRCUIT)**

Rev.1.1\_10

**S-8813 Series**

**2. S-881300BPE**

**Table 4 Electrical Characteristics**

(Unless otherwise specified,  $V_{IN} = 3.0\text{ V}$ , current setting voltage = 1.8 V,  $T_a = 25^\circ\text{C}$ )

Item	Symbol	Conditions	Min.	Typ.	Max.	Unit	Test Circuit
Operation input voltage	$V_{IN}$	—	2.7	—	4.5	V	2
Stabilized output current	$I_{OUT}$	$V_{IN} = 3.0\text{ V to }4.5\text{ V}$ $V_{IOUT1,2,3}^{*1} \leq 3.6\text{ V}$	23	—	—	mA	
		$V_{IN} = 3.0\text{ V to }4.5\text{ V}$ $V_{IOUT1,2,3}^{*1} \leq 4.0\text{ V}$	18	—	—		
		$V_{IN} = 2.7\text{ V to }3.0\text{ V}$ $V_{IOUT1,2,3}^{*1} \leq 3.6\text{ V}$	14	—	—		
Output current $V_{IOUT}$ characteristics	$\Delta I_{OUT1}$	$V_{IN} = 3.0\text{ V}$ , $V_{IOUT} = 3.0\text{ V to }4.0\text{ V}$	—	0.5	1		
Output current input stability	$\Delta I_{OUT2}$	$V_{IN} = 3.0\text{ V to }4.5\text{ V}$ $V_{IOUT} \leq 3.6\text{ V}$	—	0.5	1		
Output current accuracy	$\frac{\Delta I_{OUT1}}{I_{OUT}}$	$I_{OUT1,2,3} = 18\text{ mA}$	-5.0	—	+5.0	%	
Inter-pin output current variation	$\Delta I_M$	$V_{IOUT} = 3.6\text{ V}$	-1.0	—	+1.0		
Ripple voltage	$V_{RIP}$	$V_{IN} = 2.7\text{ V to }4.5\text{ V}$	—	—	100	mV <sub>p-p</sub>	
Maximum oscillation frequency	$f_{osc}$	$V_{CP\text{OUT}} = 4.75\text{ V}$ Measure waveform at C- pin	540	600	660	kHz	
Efficiency <sup>*2</sup>	$\eta$	$V_{IN} = 3.0\text{ V}$	—	82	—	%	2
Operation consumption current	$I_{SS1}$	$V_{IN} = 2.7\text{ V to }4.5\text{ V}$ $V_{CP\text{OUT}} = 4.75\text{ V}$	—	1	1.5	mA	1
Standby consumption current	$I_{SSS}$	$V_{IN} = 2.7\text{ V to }4.5\text{ V}$	—	0.3	1	$\mu\text{A}$	
Power-off pin input voltage (high level)	$V_{SH}$	$V_{IN} = 2.7\text{ V to }4.5\text{ V}$	2.0	—	—	V	
Power-off pin input voltage (low level)	$V_{SL}$	$V_{IN} = 2.7\text{ V to }4.5\text{ V}$	—	—	0.3		
Power-off pin input current (high level)	$I_{SH}$	$V_{IN} = 2.7\text{ V to }4.5\text{ V}$	-0.1	—	0.1	$\mu\text{A}$	
Power-off pin input current (low level)	$I_{SL}$	$V_{IN} = 2.7\text{ V to }4.5\text{ V}$	-0.1	—	0.1		
Soft start time	$t_{SS}$	$V_{IN} = 2.7\text{ V to }4.5\text{ V}$	0.3	1.5	3	ms	2
VISET pin voltage	$V_{VISET}$	$V_{IN} = 2.7\text{ V to }4.5\text{ V}$	0.5	—	1.8	V	

\*1.  $V_{IOUT1,2,3}$  are the voltages of the IOUT pin.

\*2. "Efficiency" in the electrical characteristics means the efficiency of the charge pump circuit block. The ideal efficiency is indicated by the following expression.

$$\text{Efficiency} = [V_{CP\text{OUT}} \times (I_{OUT1} + I_{OUT2} + I_{OUT3})] / [2.0 \times V_{IN} \times (I_{OUT1} + I_{OUT2} + I_{OUT3})]$$

The ideal efficiency including the constant current circuit is expressed as following expression.

$$\text{Efficiency} = [(V_{IOUT1} \times I_{OUT1}) + (V_{IOUT2} \times I_{OUT2}) + (V_{IOUT3} \times I_{OUT3})] / [2.0 \times V_{IN} \times (I_{OUT1} + I_{OUT2} + I_{OUT3})]$$

**Remark** The numbers in the "test circuit" column correspond to the circuit numbers in the "Measurement Circuits" section.

■ **Measurement Circuits**

1.

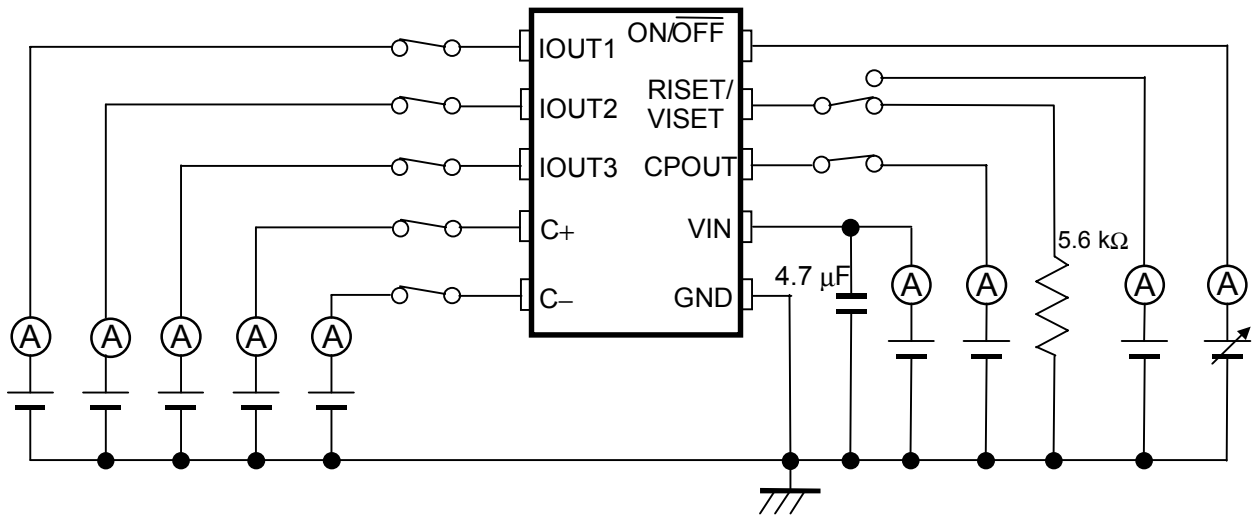

2.

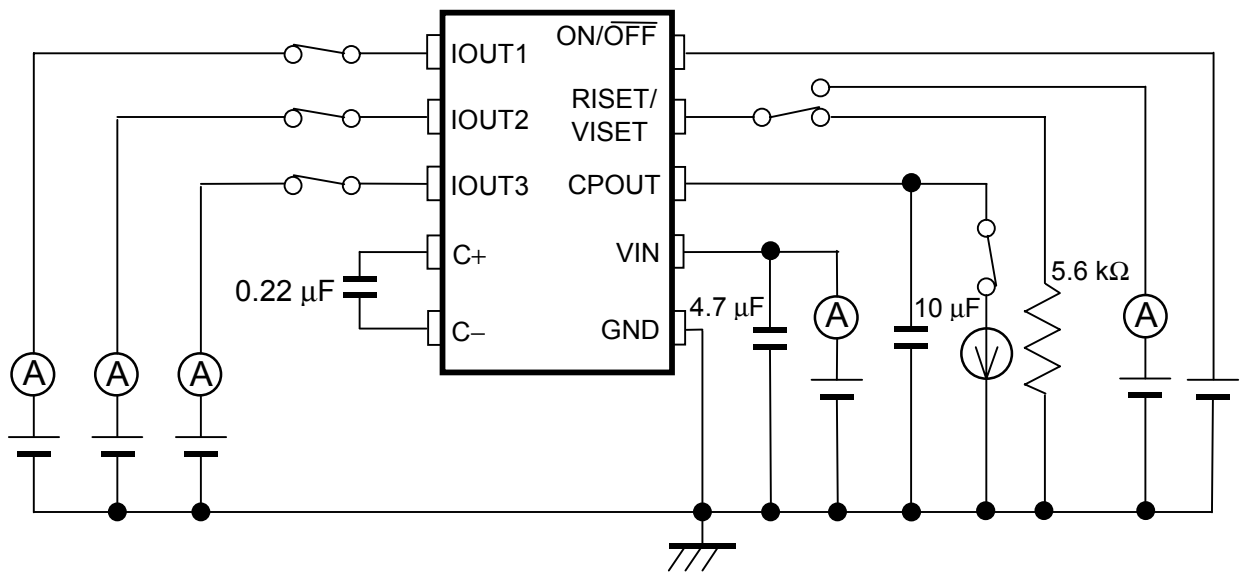

**Figure 3 Measurement Circuits**

# 3-CHANNEL WHITE LED DRIVER IC (CHARGE PUMP IC WITH A BUILT-IN CONSTANT-CURRENT CIRCUIT)

Rev.1.1\_10

S-8813 Series

## ■ Operation

### 1. Basic Operation

The S-8813 series controls by using the pulse frequency modulation (PFM) method. The SW1 to SW4 switching transistors are switched ON/OFF with the clock generated by the internal oscillator (OSC), and operates the step-up charge pump.

The output voltage is feed back and the voltage split by feedback resistances  $R_s$  and  $R_f$  and reference voltage ( $V_{ref}$ ) are compared by a comparator. This comparator signal is used to modulate the oscillation pulse frequency in order to keep the output voltage constant.

Using this constant output voltage as the voltage source, a constant current is created using  $V_{ref}$  and the external resistance value applied to the RISET pin, and this constant current is supplied as the current output to the three channels of output pins (IOUT1 to IOUT3). Therefore, even if the white LED  $V_F$  (forward voltage) varies between 3 V and 4 V, a constant current can be supplied, making it possible to reduce fluctuations in brightness and keep white LEDs shining at a constant brightness.

#### S-881300CPE

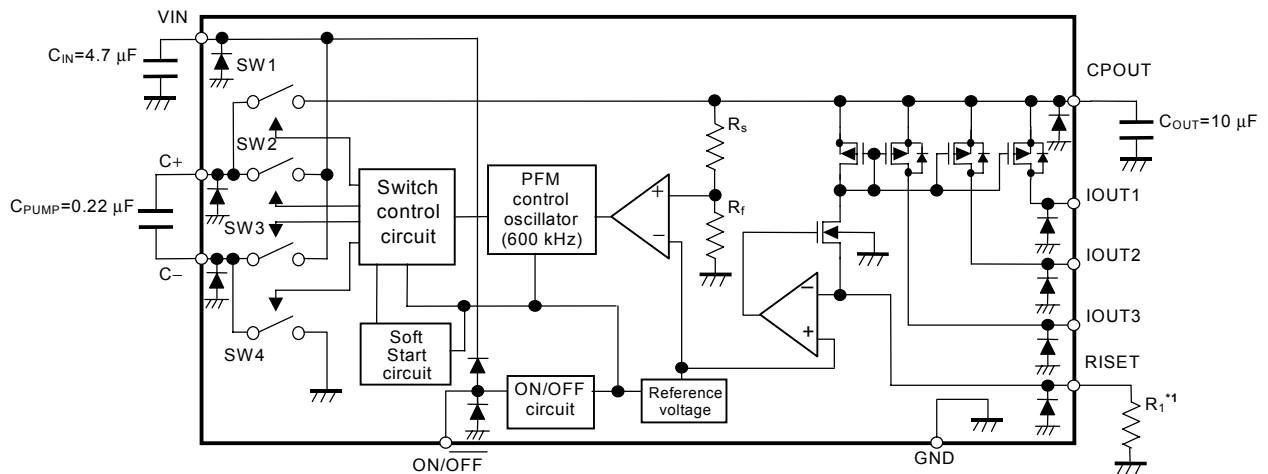

#### S-881300BPE

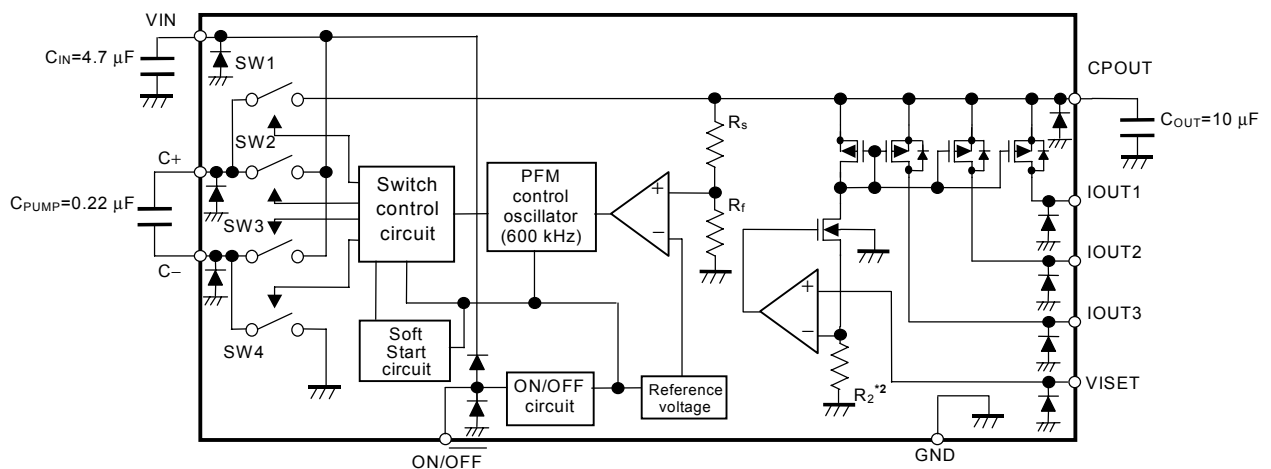

\*1. Current setting resistance

\*2. Internal resistance

**Figure 4 Block Diagram**

**2. Step-up Charge Pump**

The step-up charge pump steps up the voltage by switching ON/OFF the SW1 to SW4 switching transistors.

First, in order to charge the pump capacitance ( $C_{PUMP}$ ), set SW1 to OFF, SW2 to ON, SW3 to OFF, and SW4 to ON (charge cycle). Following charging the electricity, in order to discharge the charged electricity to the output capacitance ( $C_{OUT}$ ), SW1 set the switches as to ON, SW2 to OFF, SW3 to ON, and SW4 to OFF (discharge cycle).

The input voltage can be stepped up to a constant voltage value by repeating this charge cycle and discharge cycle.

In the S-8813 Series, the  $V_{IN}$  voltage range of 2.7 V to 4.5 V is stepped up to  $V_{CPOUT} = 5 V$ .

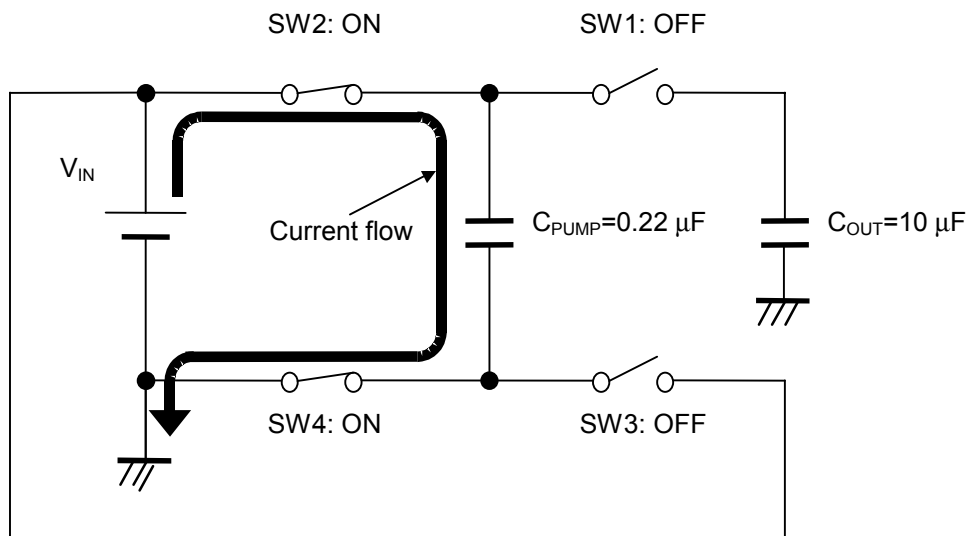

**Figure 5 Charge Cycle**

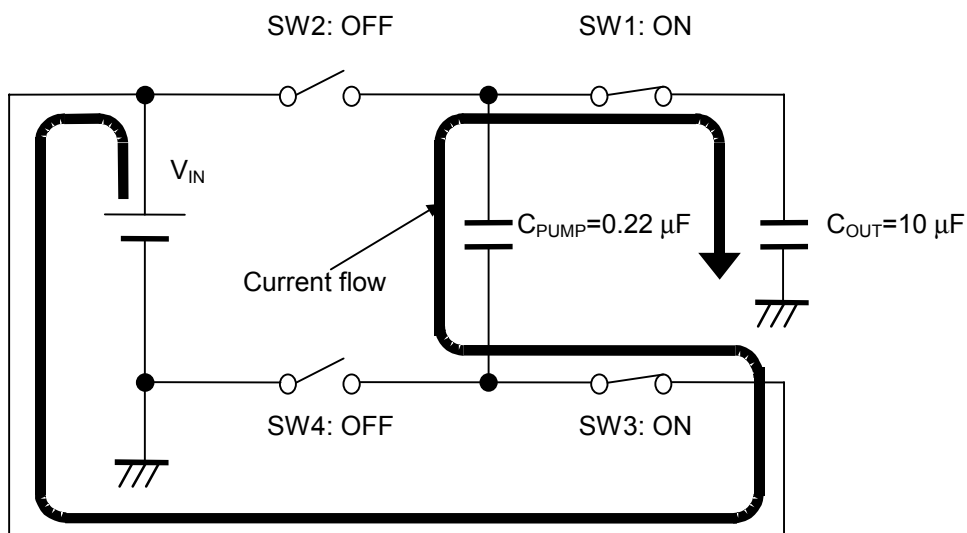

**Figure 6 Discharge Cycle**



**3. Constant current output circuit**

The S-8813 Series features a three-channel constant current output circuit and enables driving of white LEDs in the current mode.

In the case of the S-8813 Series, the constant current value can be controlled using one of the two following methods according to the product.

In the case of the S-881300CPE, the desired constant current can be obtained with an external resistance value. Since a reference voltage of  $1\text{ V} \pm 2\%$  is output to the RISET pin, application of resistance  $R_1$  of  $20\text{ k}\Omega$  to  $5.6\text{ k}\Omega$  between the RISET pin and GND results in the flow of a constant current of  $50\text{ }\mu\text{A}$  to  $178\text{ }\mu\text{A}$  in the current setting resistance ( $R_1$ ) due to the  $I = V/R$  relationship. Amplifying this constant current 100 times and outputting it to  $I_{OUT1}$ ,  $I_{OUT2}$ , and  $I_{OUT3}$  can obtain a constant current of between  $5\text{ mA}$  to  $17.8\text{ mA}$ /channel.

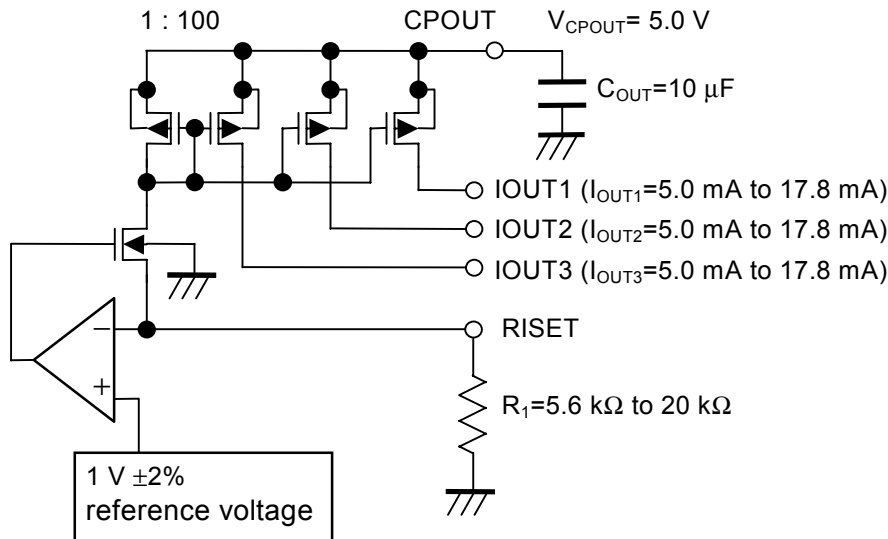

**Figure 7 Constant Current Circuit (S-881300CPE)**

On the other hand, a constant current of the desired value can also be obtained for the S-881300BPE by supplying the reference voltage to the VISET pin externally. Within the IC, a resistance of  $10\text{ k}\Omega$  is applied between the VISET pin and GND. The application of a reference voltage of between  $0.5\text{ V}$  and  $1.8\text{ V}$  to the VISET pin results in the flow of a current between  $50\text{ }\mu\text{A}$  and  $180\text{ }\mu\text{A}$  in the internal resistor ( $R_2$ ) due to the  $I = V/R$  relationship. Amplifying this constant current 100 times and outputting it to  $I_{OUT1}$ ,  $I_{OUT2}$ , and  $I_{OUT3}$  can obtain a constant current of between  $5\text{ mA}$  to  $18\text{ mA}$ /channel.

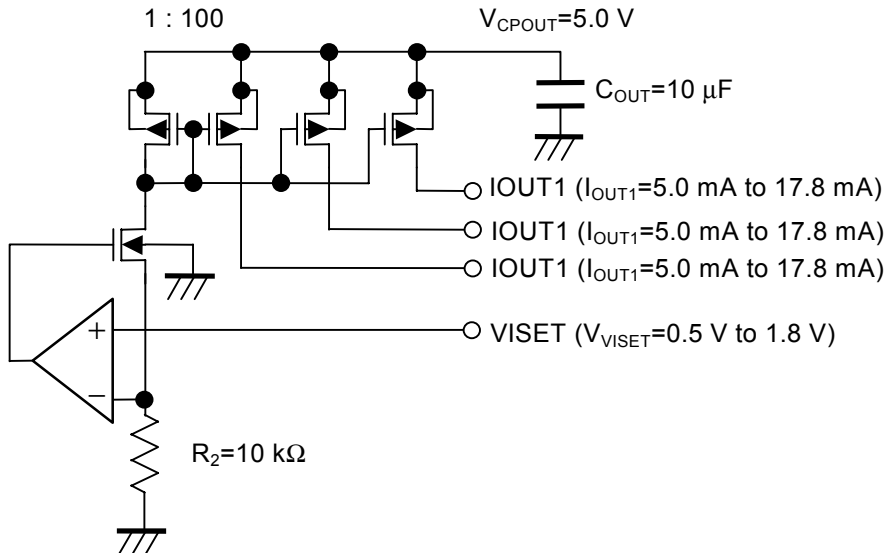

**Figure 8 Constant Current Circuit (S-881300BPE)**

#### 4. ON/OFF Pin (Power Off Pin)

Setting the ON/OFF pin to the Low level ("L") causes the voltage of the CPOUT pin to change to the GND potential and simultaneously the operation of all the internal circuit to stop. At this time, the consumption current is largely reduced, to a level of approximately 0.3  $\mu$ A.

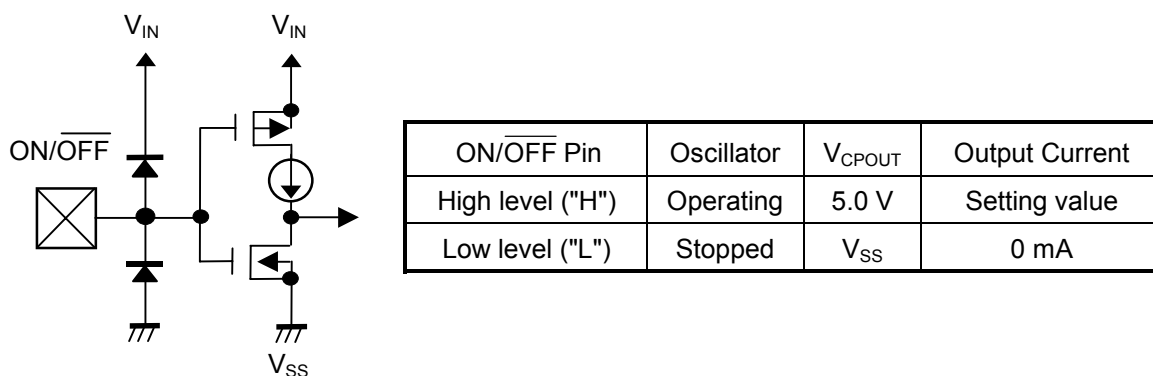

**Figure 9 Equivalent Circuit of ON/OFF Pin**

#### 5. Soft Start Function

The S-8813 Series features a built-in soft start circuit. Upon power application or when the ON/OFF pin is switched from "L" to "H", the output voltage gradually rises over the soft start time, and the output current is gradually output as a result. This soft start function reduces the input current rush.

#### 6. External Capacitor Selection

##### 6.1 Input and Output Capacitors ( $C_{IN}$ , $C_{OUT}$ )

The input capacitor ( $C_{IN}$ ) lowers the power supply impedance and averages the input current, resulting in improved efficiency.

The  $C_{IN}$  value is selected according to the impedance of the power supply that is used. Select a ceramic capacitor with a small equivalent series resistance (ESR). Although this figure varies according to the impedance of the power supply that is used as well as the load current value, it is generally in the range of 4.7  $\mu$ F to 10  $\mu$ F.

For the output capacitor ( $C_{OUT}$ ), select a ceramic capacitor with a small ESR for smoothing the ripple voltage. A value of 10  $\mu$ F is recommended for the capacitance value. Use of a capacitor with a capacitance lower than 10  $\mu$ F results in a larger ripple voltage as well as a larger ripple current for the output current.

Conversely, use of a capacitor with a capacitance greater than 10  $\mu$ F results in the output voltage not being able to rise up to 5.0 V and the impossibility to obtain the desired output current.

##### 6.2 Pump Capacitor ( $C_{PUMP}$ )

The pump capacitor ( $C_{PUMP}$ ) is required for stepping up the voltage. Select a ceramic capacitor with a small ESR. A capacitance value of 0.22  $\mu$ F is recommended. Use of a capacitor with a capacitance greater than 0.22  $\mu$ F results in a larger ripple voltage as well as a larger ripple current for the output current. Conversely, use of a capacitor with a capacitance lower than 0.22  $\mu$ F results in the output voltage not being able to rise up to 5.0 V and the impossibility to obtain the desired output current.

**■ Application Circuit Examples**

**1. Variable Current Setting Resistance Type**

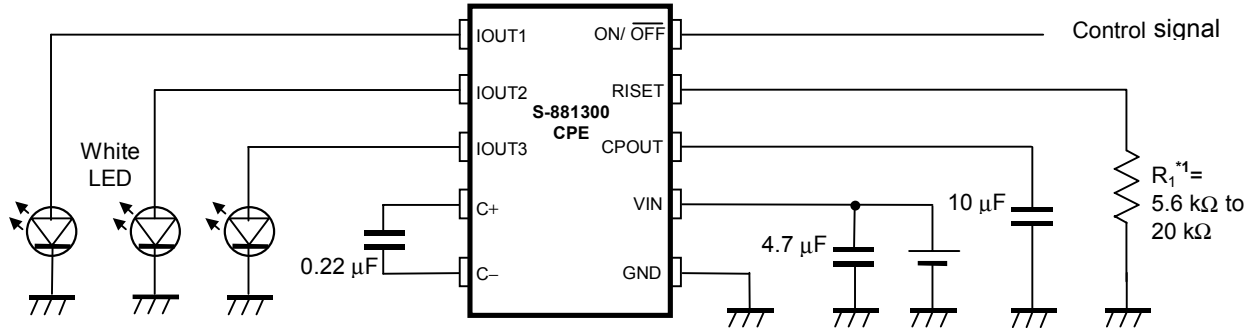

**Figure 10 Application Circuit 1 (S-881300CPE)**

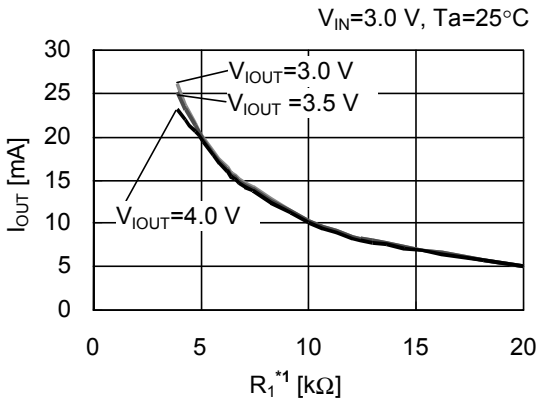

**Figure 11  $R_1^{*1}$  Dependence (S-881300CPE)**

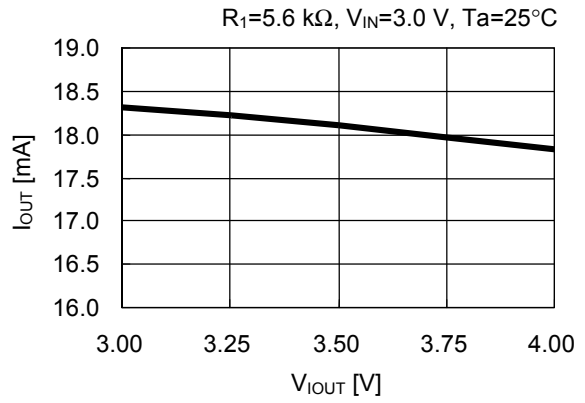

**Figure 12  $V_{IOUT}$  Dependence (S-881300CPE)**

\*1. Current setting resistance

**2. Variable Voltage Type**

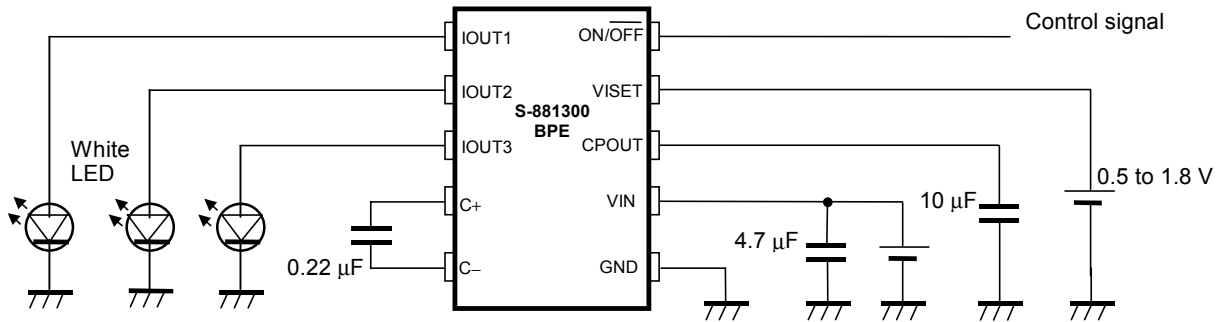

**Figure 13 Application Circuit 2 (S-881300BPE)**

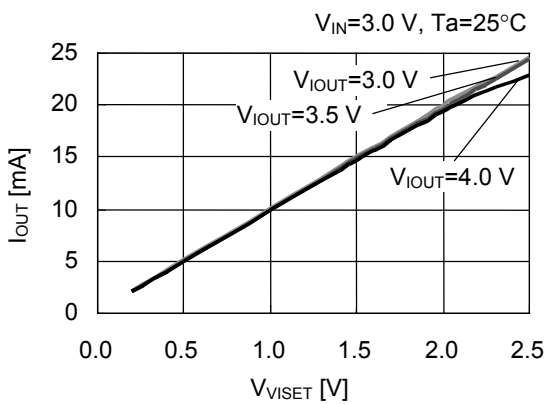

**Figure 14  $V_{ISET}$  Dependence (S-881300BPE)**

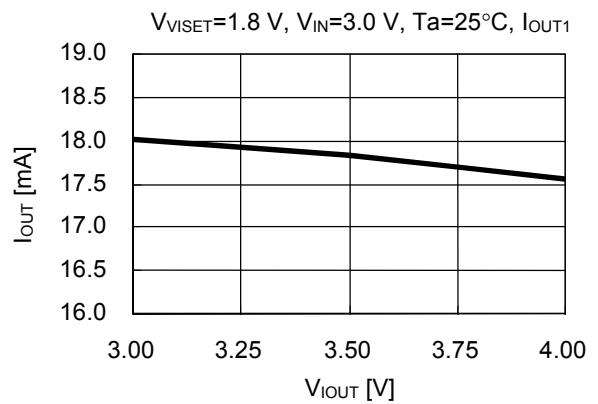

**Figure 15  $V_{IOU}$  Dependence (S-881300BPE)**

# 3-CHANNEL WHITE LED DRIVER IC (CHARGE PUMP IC WITH A BUILT-IN CONSTANT-CURRENT CIRCUIT)

Rev.1.1\_10

S-8813 Series

### 3. Regulating Luminance Circuit via PWM control signal (It corresponds only to S-881300CPE.)

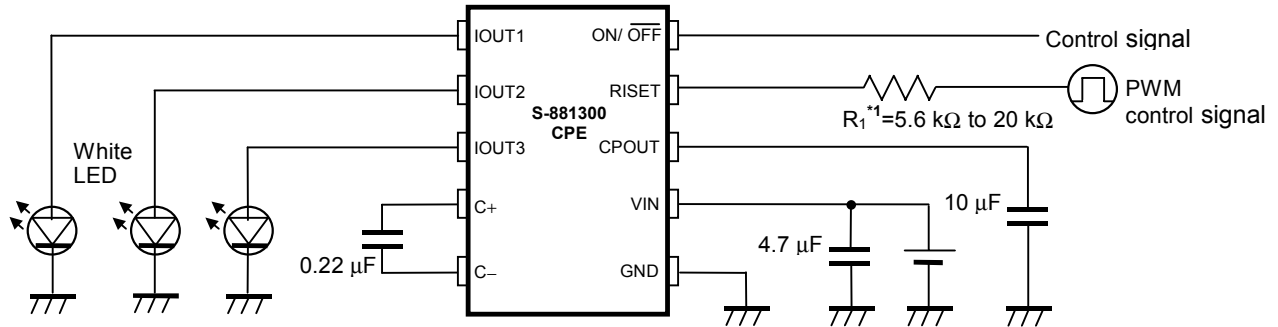

**Figure 16 Application Circuit 3 (S-881300CPE)**

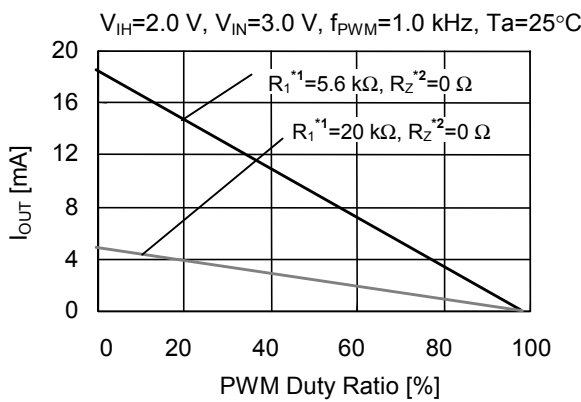

**Figure 17 I<sub>OUT</sub>-PWM Duty Ratio Dependence (R<sub>1</sub><sup>\*1</sup> Dependence)**

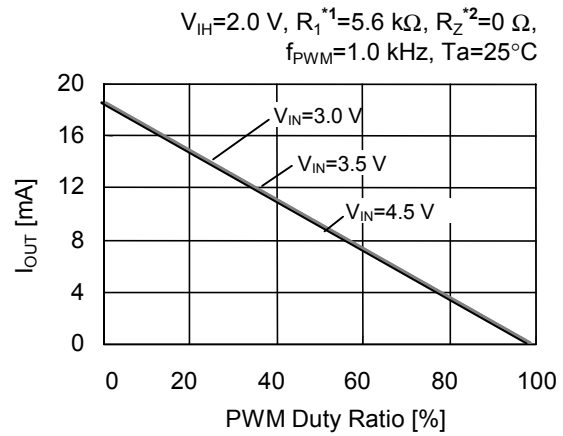

**Figure 18 I<sub>OUT</sub>-PWM Duty Ratio Dependence (V<sub>IN</sub> Dependence)**

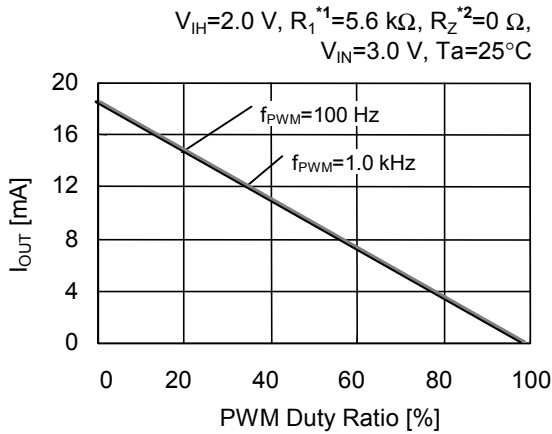

**Figure 19 I<sub>OUT</sub>-PWM Duty Ratio Dependence (f<sub>PWM</sub> Dependence)**

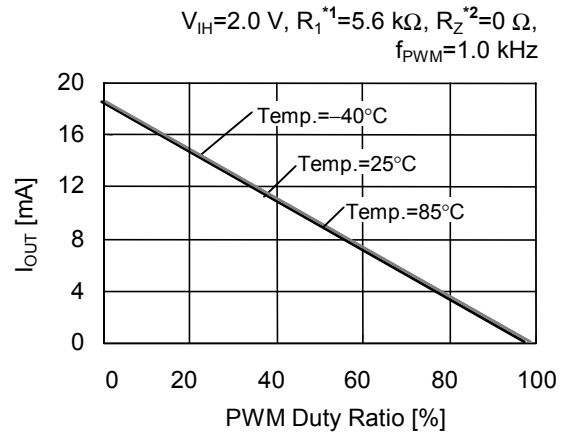

**Figure 20 I<sub>OUT</sub>-PWM Duty Ratio Dependence (Temp. Dependence)**

\*1. Current setting resistance

\*2. The output impedance of the PWM output control signal source when the PWM control signal is "L"

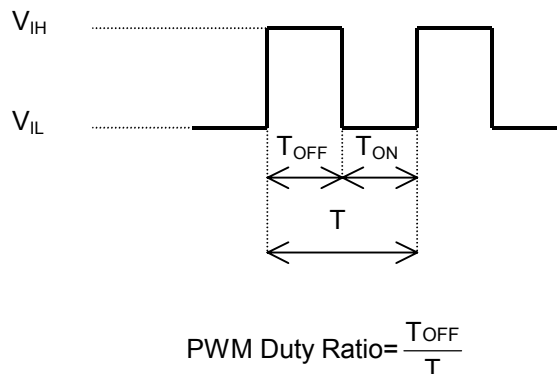

**Figure 21 Wave Form Example of PWM Control signal**

PWM Control Signal Conditions:

	Min.	Typ.	Max.
$f_{\text{PWM}}$	100 Hz	—	1.0 kHz
$V_{\text{P-P}}$	2.0 V	—	4.5 V
$V_{\text{IH}}$	2.0 V	—	4.5 V
$V_{\text{IL}}$	0 V	—	0 V

$f_{\text{PWM}}$ : Pulse frequency  
 $V_{\text{P-P}}$ : Pulse amplitude  
 $V_{\text{IH}}$ : Pulse input voltage (“H”)  
 $V_{\text{IL}}$ : Pulse input voltage (“L”)

Output Impedance of the PWM Output Control Signal Source ( $R_Z$ ): Max.500  $\Omega$

Calculation of  $I_{\text{OUT}}$  According to PWM Duty Ratio:  $I_{\text{OUT}} = 1 \text{ V} / (R_1 + R_Z) \times 100 \times (1 - \text{Duty ratio})$

Ideally, when the duty ratio is 0%,  $I_{\text{OUT}}$  value is the 100 times value of the R1SET pin voltage (1 V) divided by the resistance of  $R_1$ . However, the impedance from the R1SET pin to the GND will serve as  $R_1 + R_Z$  in actual operation.  $R_Z$  means the output impedance of the PWM control signal source when the PWM control signal is low level. Therefore, the  $I_{\text{OUT}}$  value varies depend on the  $R_Z$  value.

- Caution 1. Fix the PWM output to low level during standby (when the ON/OFF pin is low level). If the PWM Output is set to high level, leak current will flow.**
- 2. When the PWM duty is set to 100%, the current to the LED will be switched off. However, the IC will still keep operation. This is not the same as standby mode, and so the current consumption will be the same as in normal operation mode.**
  - 3. The duty ratio indicates the percentage of the high-level pulse width to one period.**

■ Precautions

- Regarding the wiring to the VIN pin, CPOUT pin, C+ pin, C– pin and GND pin, be careful to perform pattern wiring so as to obtain low impedance.
- Always connect a capacitor to the CPOUT pin, C+ pin, and C– pin.
- Connect C<sub>IN</sub> and C<sub>OUT</sub> in the vicinity of the IC and sufficiently strengthen the wiring for GND pin and VIN pin in order to lower the impedance of the wiring resistance, etc. High impedance may cause unstable operation. Moreover, in selecting C<sub>IN</sub> and C<sub>OUT</sub>, perform a full evaluation of the actual usage conditions.
- Connect C<sub>PUMP</sub> in the vicinity of the IC and sufficiently strengthen the wiring for the C+ pin and C– pin in order to lower the impedance of the wiring resistance, etc. High impedance may cause instable operation. Moreover, in selecting C<sub>PUMP</sub>, perform a full evaluation of the actual usage conditions.
- The oscillation pulse width may be small with a light load; however, this causes problems in the IC operation.
- The ON/ $\overline{\text{OFF}}$  pin is configured as shown in Figure 9 and is neither pulled up or down internally, so do not use this pin in a floating state.  
When not using the ON/ $\overline{\text{OFF}}$  pin, connect it to the VIN pin.  
Moreover, please do not impress voltage higher than V<sub>IN</sub>+0.3 V to an ON/ $\overline{\text{OFF}}$  pin. Current flows for a VIN pin through the protection diode inside IC.
- Do not apply an electrostatic discharge to this IC that exceeds the performance ratings of the built-in electrostatic protection circuit.
- Be careful about the usage conditions for the input/output voltages and output current to make sure that dissipation within the IC does not exceed the allowable power dissipation of the package.  
For reference, the calculation of the power consumption in this IC is shown below.

$$P_D = (V_{IN} \times 2.0 - V_{I_{OUT1,2,3}}) \times (I_{OUT1} + I_{OUT2} + I_{OUT3})$$

Reference: V<sub>IN</sub>=4.2 V, V<sub>I<sub>OUT1,2,3</sub></sub>=3.6 V, I<sub>OUT1,2,3</sub>=18 mA

$$P_D = (4.2 \times 2.0 - 3.6) \times 0.054 = 259 \text{ mW}$$

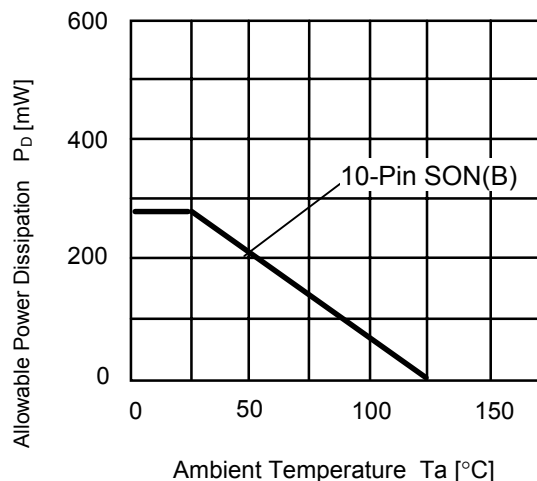
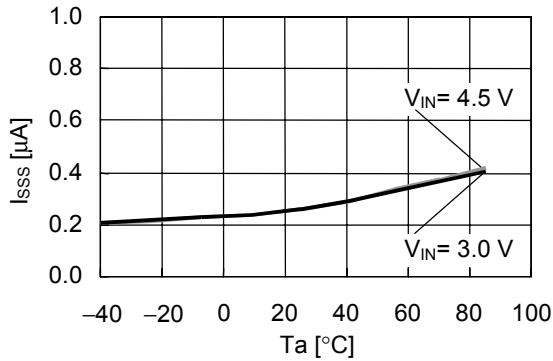

**Figure 22 Allowable Power Dissipation of Package (Before Mounting)**

- The contents of this document are subject to change in order to reflect improvements made to the IC therein, so be sure to use the latest version of this document.
- Seiko Instruments Inc. shall not be responsible for any patent infringements caused by products using the S-8813 Series in connection with the method in which the S-8813 Series is used in such products, the product specifications, or the country of destination.

**Major Temperature Characteristics Examples**

1. Standby Consumption Current ( $I_{SSS}$ ) vs. Ambient Temperature ( $T_a$ ) Characteristics



2. Power Off Pin Input Voltage "H" ( $V_{SH}$ ) vs. Ambient Temperature ( $T_a$ ) Characteristics

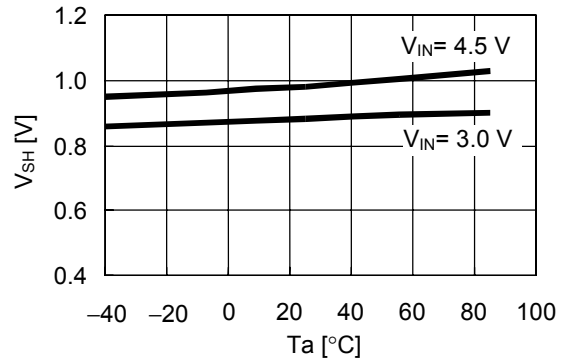

3. Power Off Pin Input Voltage "L" ( $V_{SL}$ ) vs. Ambient Temperature ( $T_a$ ) Characteristics

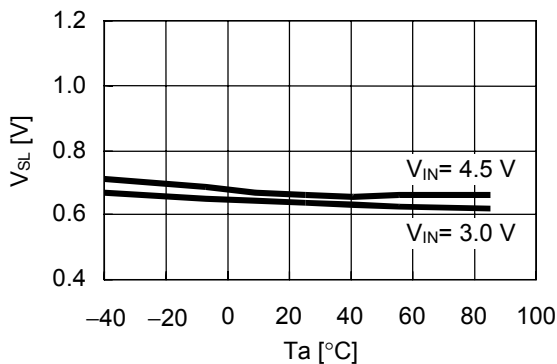

4. RISET Pin Voltage ( $V_{RISET}$ ) vs. Ambient Temperature ( $T_a$ ) Characteristics

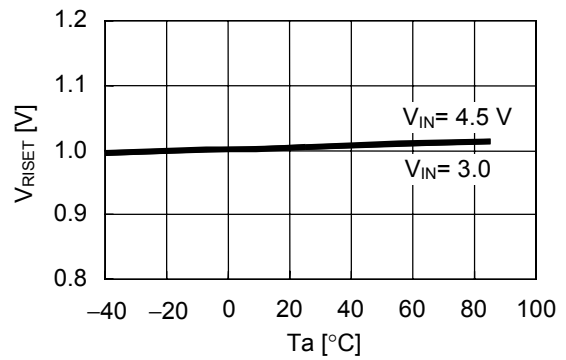

5. Operation Consumption Current ( $I_{SS1}$ ) vs. Ambient Temperature ( $T_a$ ) Characteristics

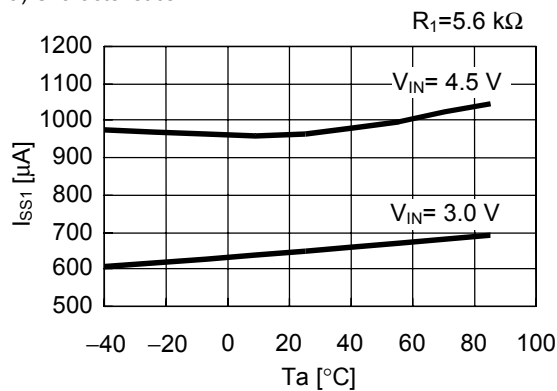

6. Ripple Voltage ( $V_{RIP}$ ) vs. Ambient Temperature ( $T_a$ ) Characteristics

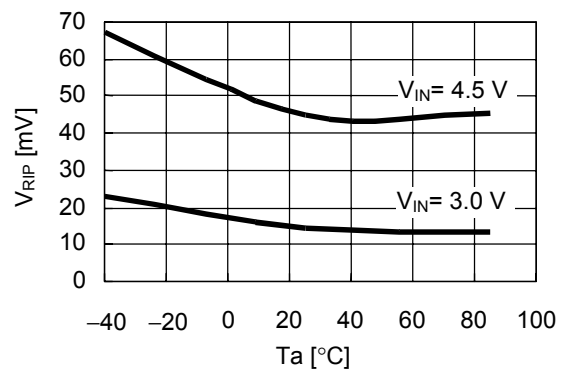



# 3-CHANNEL WHITE LED DRIVER IC (CHARGE PUMP IC WITH A BUILT-IN CONSTANT-CURRENT CIRCUIT)

Rev.1.1\_10

S-8813 Series

7. Maximum Oscillation Frequency ( $f_{osc}$ ) vs. Ambient Temperature ( $T_a$ ) Characteristics

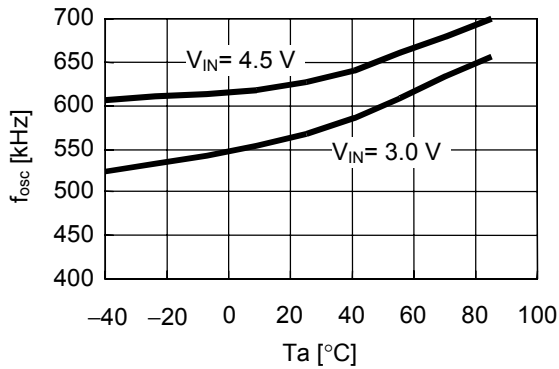

8. Soft Start Time ( $T_{SS}$ ) vs. Ambient Temperature ( $T_a$ ) Characteristics

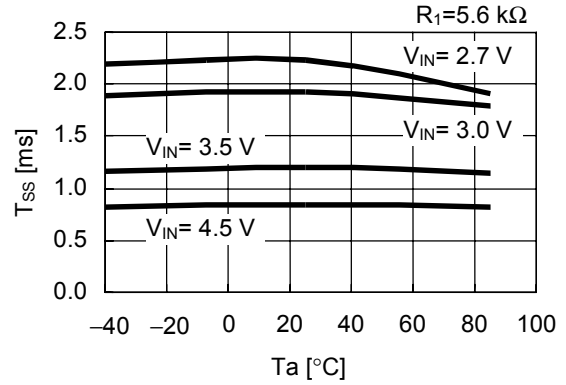

9. Stabilized Output Current ( $I_{OUT}$ ) vs. Ambient Temperature ( $T_a$ ) Characteristics

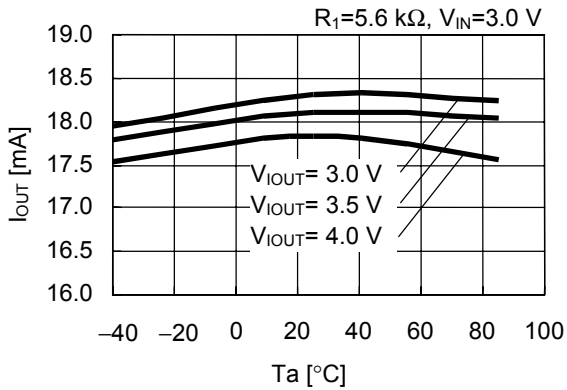

10. Stabilized Output Current ( $I_{OUT}$ ) vs. Ambient Temperature ( $T_a$ ) Characteristics

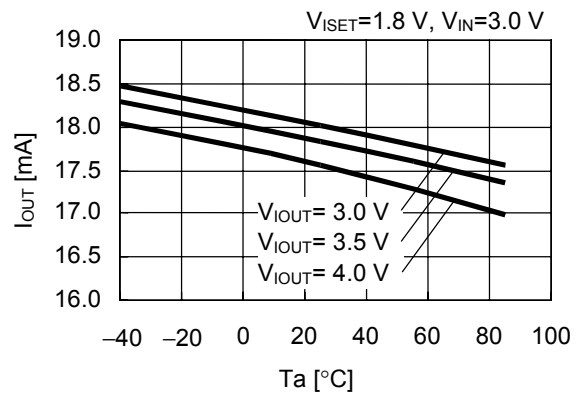

11. Inter-Pin Output Current Variation ( $\Delta I_M$ ) vs. Ambient Temperature ( $T_a$ ) Characteristics

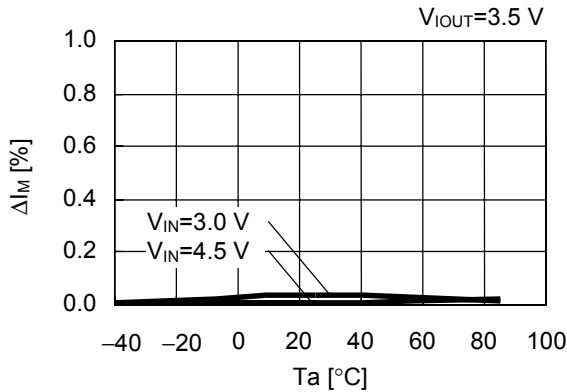

**■ Major Power Supply Dependence Characteristics Examples**

1. Standby Consumption Current ( $I_{SSS}$ ) vs. Operation Input Voltage ( $V_{IN}$ ) Characteristics
2. Power-Off Pin Input Voltage "H" ( $V_{SH}$ ) vs. Operation Input Voltage ( $V_{IN}$ ) Characteristics

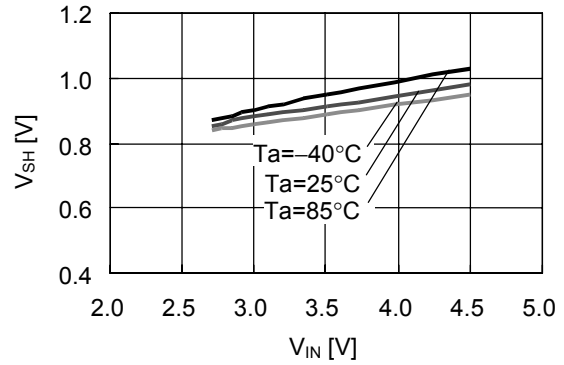
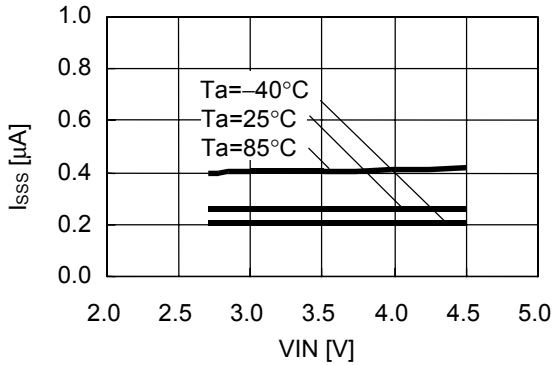

3. Power-Off Pin Input Voltage "L" ( $V_{SL}$ ) vs. Operation Input Voltage ( $V_{IN}$ ) Characteristics

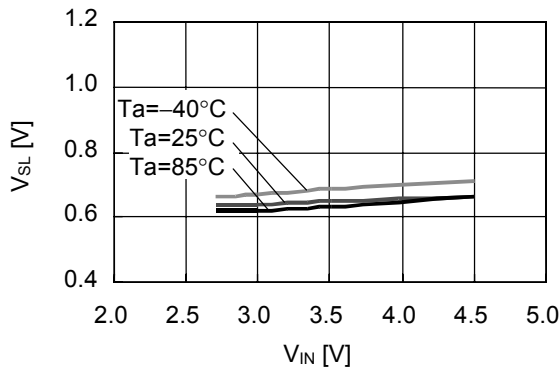

4. RISET Pin Voltage ( $V_{RISET}$ ) vs. Operation Input Voltage ( $V_{IN}$ ) Characteristics

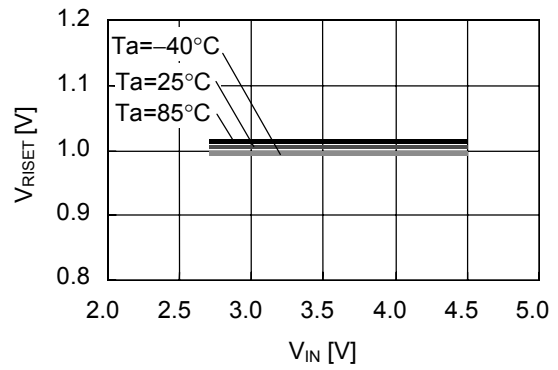

5. Efficiency\*1 ( $\eta$ ) vs. Operation Input Voltage ( $V_{IN}$ ) Characteristics

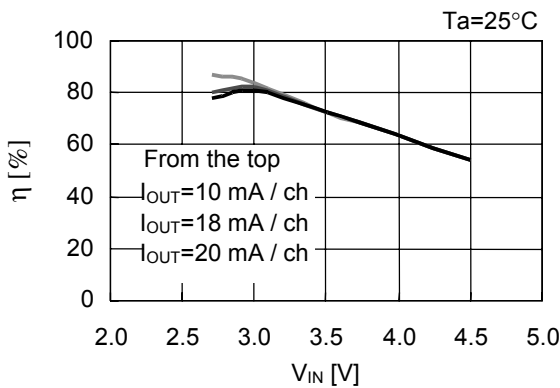

6. CPOUT Pin Voltage ( $V_{CPOUT}$ ) vs. Operation Input Voltage ( $V_{IN}$ ) Characteristics

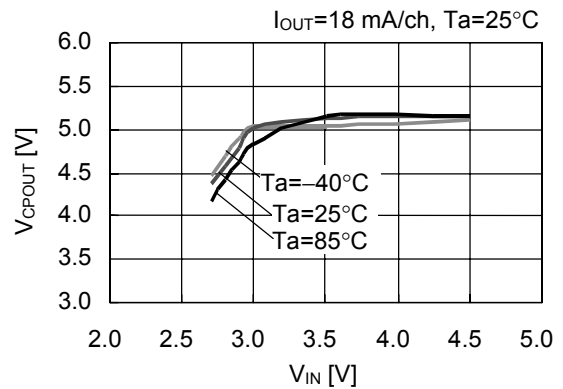

\*1. "Efficiency" in the electrical characteristics means the efficiency of the charge pump circuit block. The ideal efficiency is indicated by the following expression.

$$\text{Efficiency} = [V_{CPOUT} \times (I_{OUT1} + I_{OUT2} + I_{OUT3})] / [2.0 \times V_{IN} \times (I_{OUT1} + I_{OUT2} + I_{OUT3})]$$

The ideal efficiency including the constant current circuit is expressed as following expression.

$$\text{Efficiency} = [(V_{IOUT1} \times I_{OUT1}) + (V_{IOUT2} \times I_{OUT2}) + (V_{IOUT3} \times I_{OUT3})] / [2.0 \times V_{IN} \times (I_{OUT1} + I_{OUT2} + I_{OUT3})]$$

# 3-CHANNEL WHITE LED DRIVER IC (CHARGE PUMP IC WITH A BUILT-IN CONSTANT-CURRENT CIRCUIT)

Rev.1.1\_10

S-8813 Series

7. Operation Consumption Current ( $I_{SS1}$ ) vs. Operation Input Voltage ( $V_{IN}$ ) Characteristics

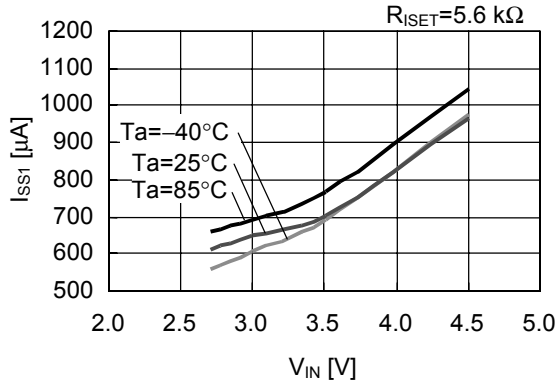

8. Ripple Voltage ( $V_{RIP}$ ) vs. Operation Input Voltage ( $V_{IN}$ ) Characteristics

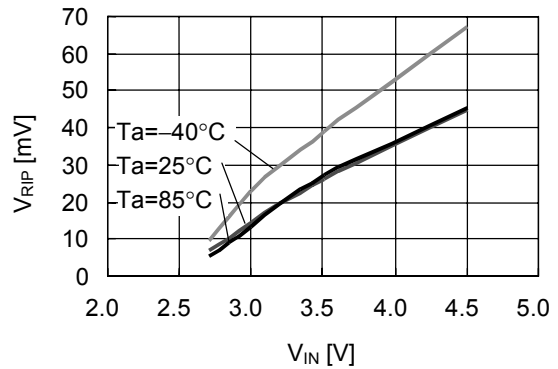

9. Maximum Oscillation Frequency ( $f_{OSC}$ ) vs. Operation Input Voltage ( $V_{IN}$ ) Characteristics

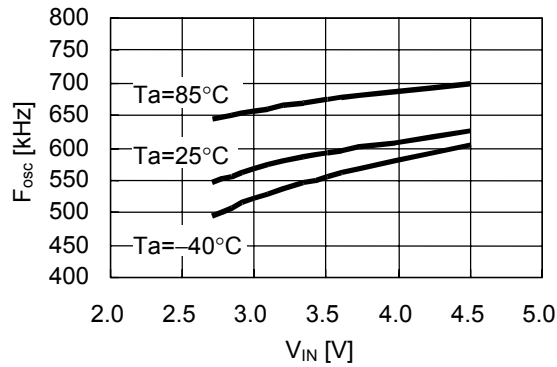

10. Soft Start Time ( $t_{SS}$ ) vs. Operation Input Voltage ( $V_{IN}$ ) Characteristics

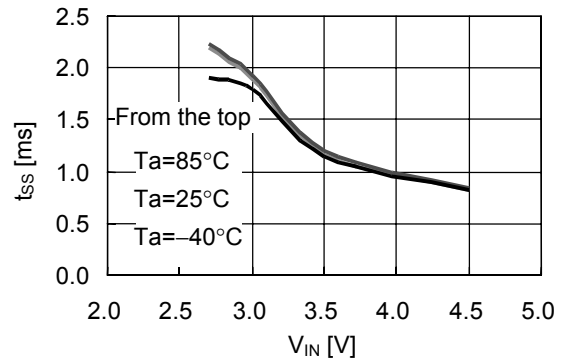

11. Stabilized Output Current ( $I_{OUT}$ ) vs. Operation Input Voltage ( $V_{IN}$ ) Characteristics

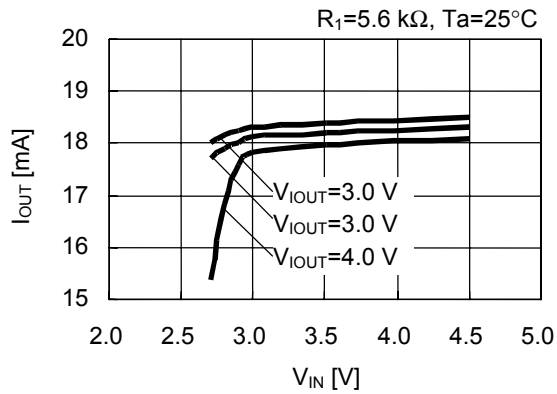

12. Stabilized Output Current ( $I_{OUT}$ ) vs. Operation Input Voltage ( $V_{IN}$ ) Characteristics

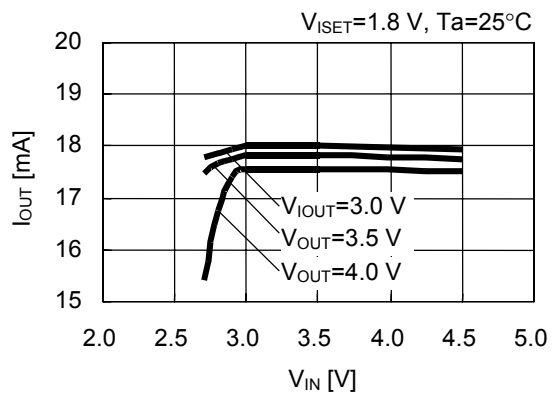

13. Inter-Pin Output Current Variation ( $\Delta I_M$ ) vs. Operation Input Voltage ( $V_{IN}$ ) Characteristics

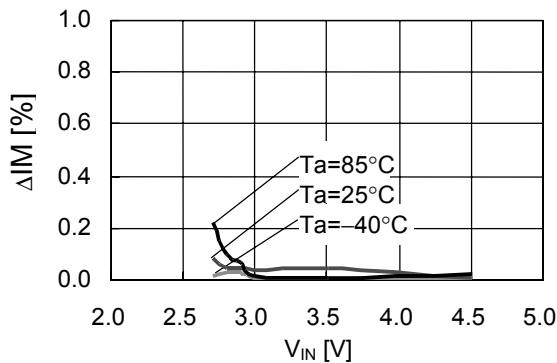

**Major Load Characteristics Examples**

1. Efficiency\*<sup>1</sup> ( $\eta$ ) vs. Stabilized Output Current ( $I_{OUT}$ ) Characteristics

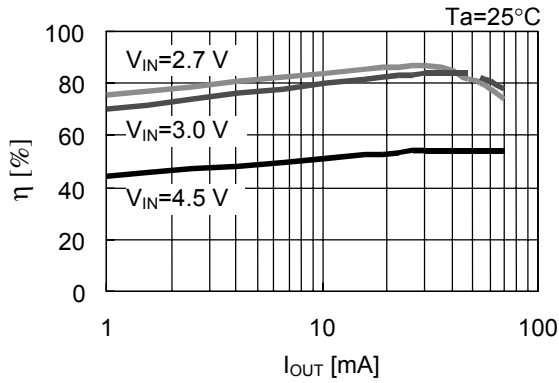

2. CPOUT Pin Voltage ( $V_{CPOUT}$ ) vs. Stabilized Output Current ( $I_{OUT}$ ) Characteristics

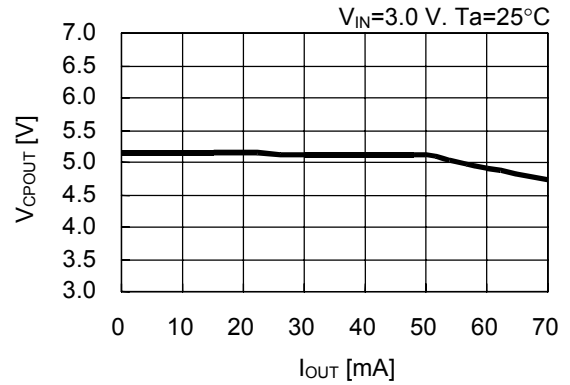

\*1. "Efficiency" in the electrical characteristics means the efficiency of the charge pump circuit block. The ideal efficiency is indicated by the following expression.

$$\text{Efficiency} = [ V_{CPOUT} \times (I_{OUT1} + I_{OUT2} + I_{OUT3}) ] / [ 2.0 \times V_{IN} \times (I_{OUT1} + I_{OUT2} + I_{OUT3}) ]$$

The ideal efficiency including the constant current circuit is expressed as following expression.

$$\text{Efficiency} = [ (V_{IOUT1} \times I_{OUT1}) + (V_{IOUT2} \times I_{OUT2}) + (V_{IOUT3} \times I_{OUT3}) ] / [ 2.0 \times V_{IN} \times (I_{OUT1} + I_{OUT2} + I_{OUT3}) ]$$

# 3-CHANNEL WHITE LED DRIVER IC (CHARGE PUMP IC WITH A BUILT-IN CONSTANT-CURRENT CIRCUIT)

Rev.1.1\_10

S-8813 Series

## ■ Transient Response Characteristics Examples

1. Power-Off Pin Response

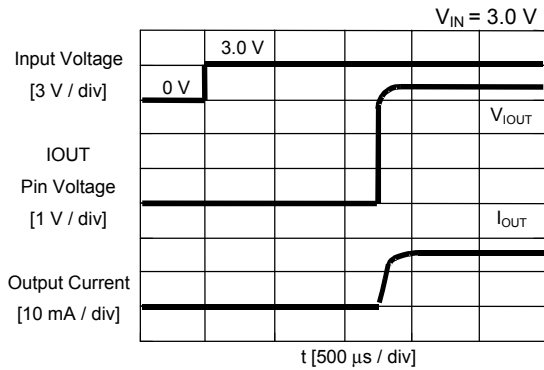

2. Power Supply Application

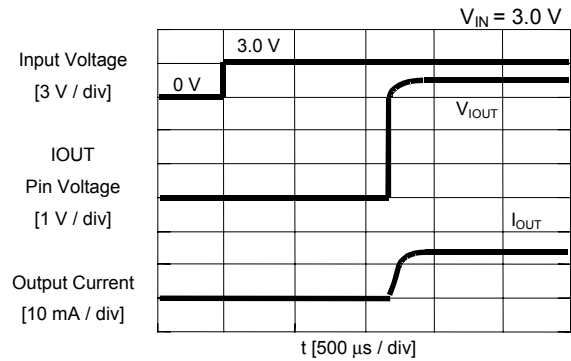

3. Power Supply Voltage Transition

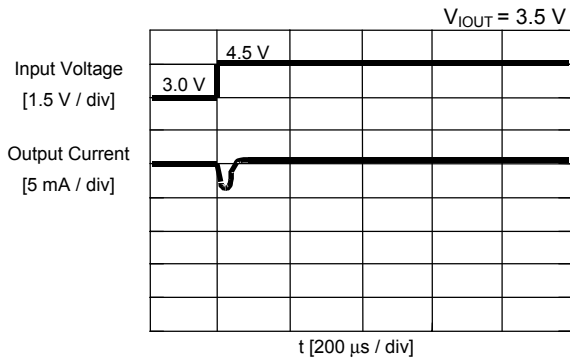

4. Power Supply Voltage Transition

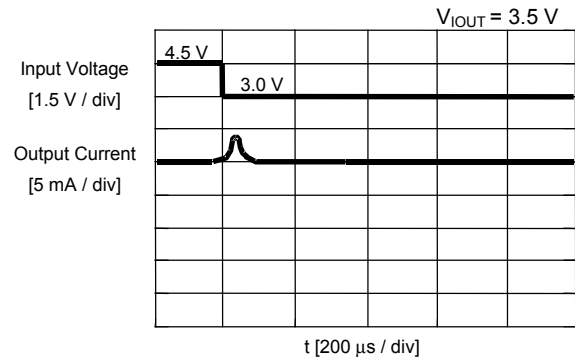

5. Current Setting Switching

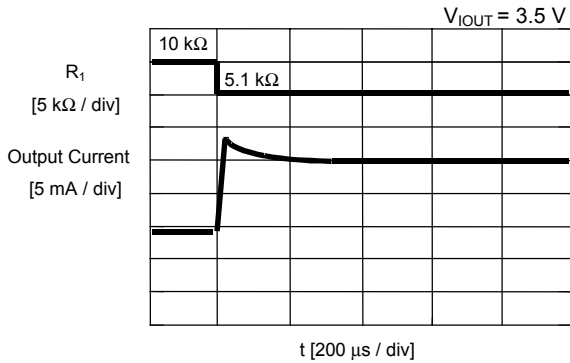

6. Current Setting Switching

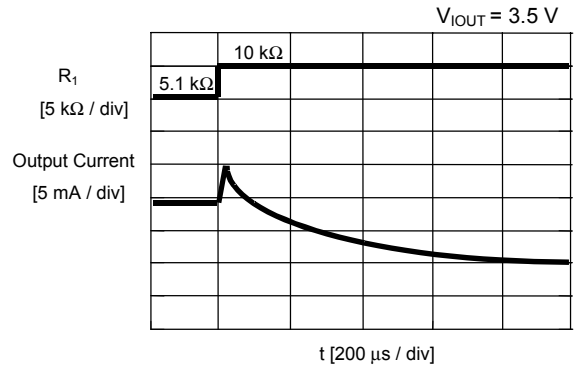

7. Ripple Characteristics (COUT 10 μF)

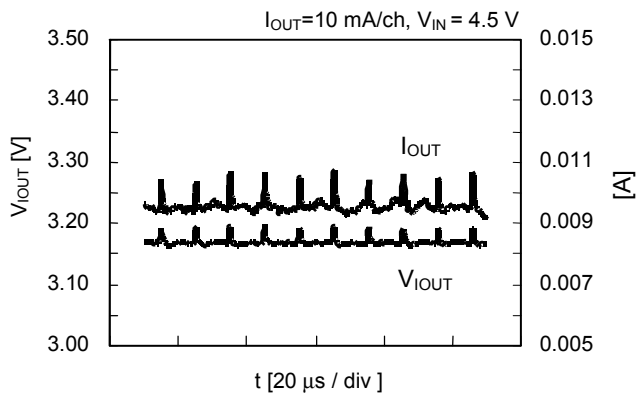

8. Ripple Characteristics (COUT 4.7 μF)

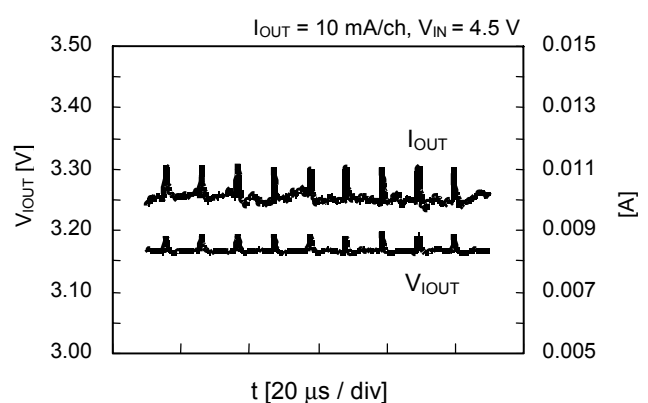

9. Ripple Characteristics ( $C_{OUT} = 1.0 \mu F$ )

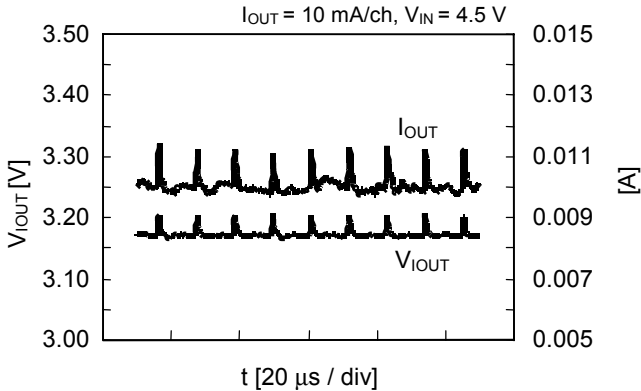

# SON10B-A

## ●Dimensions

Unit:mm

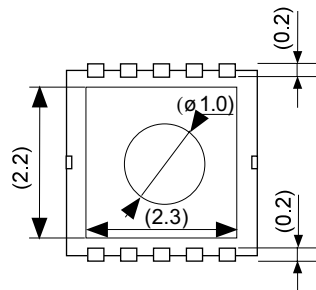
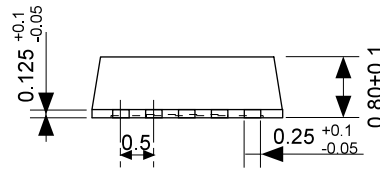
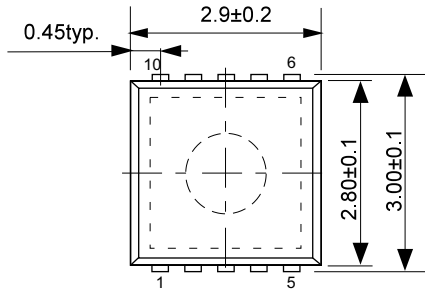

No. : PE010-A-P-SD-1.0

## ●Taping Specifications

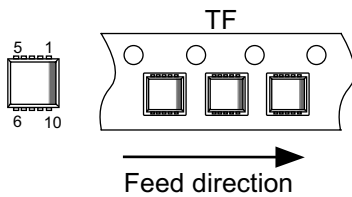
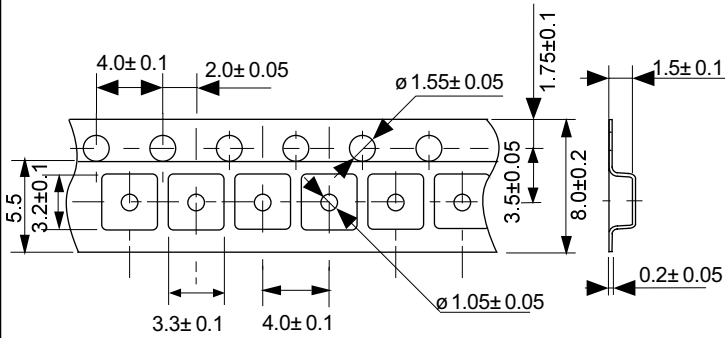

No. : PE010-A-C-SD-1.0

## ●Reel Specifications

1 reel holds 3000 ICs.

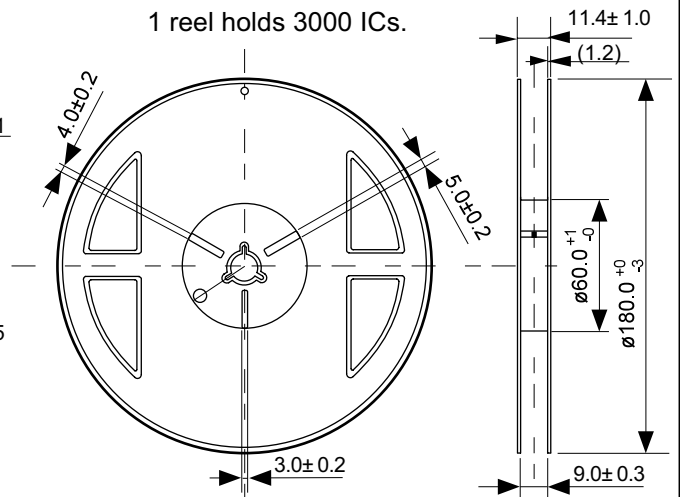

Winding core

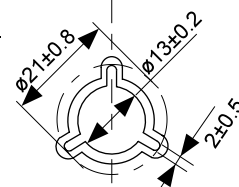

No. : PE010-A-R-SD-1.0

- The information described herein is subject to change without notice.
- Seiko Instruments Inc. is not responsible for any problems caused by circuits or diagrams described herein whose related industrial properties, patents, or other rights belong to third parties. The application circuit examples explain typical applications of the products, and do not guarantee the success of any specific mass-production design.
- When the products described herein are regulated products subject to the Wassenaar Arrangement or other agreements, they may not be exported without authorization from the appropriate governmental authority.
- Use of the information described herein for other purposes and/or reproduction or copying without the express permission of Seiko Instruments Inc. is strictly prohibited.
- The products described herein cannot be used as part of any device or equipment affecting the human body, such as exercise equipment, medical equipment, security systems, gas equipment, or any apparatus installed in airplanes and other vehicles, without prior written permission of Seiko Instruments Inc.
- Although Seiko Instruments Inc. exerts the greatest possible effort to ensure high quality and reliability, the failure or malfunction of semiconductor products may occur. The user of these products should therefore give thorough consideration to safety design, including redundancy, fire-prevention measures, and malfunction prevention, to prevent any accidents, fires, or community damage that may ensue.