

Typical Applications

- PCS Communication Systems
- Digital Communication Systems
- DECT Cordless Applications
- Commercial and Consumer Systems
- Portable Battery Powered Equipment

Product Description

The RF2125 is a high power, high efficiency linear amplifier IC. The device is manufactured on an advanced Gallium Arsenide Heterojunction Bipolar Transistor (HBT) process, and has been designed for use as the final RF amplifier in digital PCS phone transmitters and base stations requiring linear amplification operating between 1500MHz and 2200MHz. It will also function as a high efficiency amplifier for constant envelope applications such as DECT. The device is packaged in an 8-lead ceramic package with a backside ground. The device is self-contained with the exception of the output matching network and power supply feed line. It produces a typical output power level of 1W.

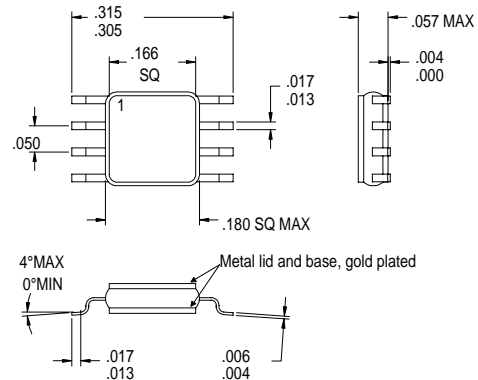

Optimum Technology Matching® Applied

- Si BJT GaAs HBT GaAs MESFET
 Si Bi-CMOS

Package Style: SOP-8-C

Features

- Single 3V to 7.5V Supply
- 1W Output Power
- 14dB Gain
- 45% Efficiency
- Power Down Mode
- 1500MHz to 2200MHz Operation

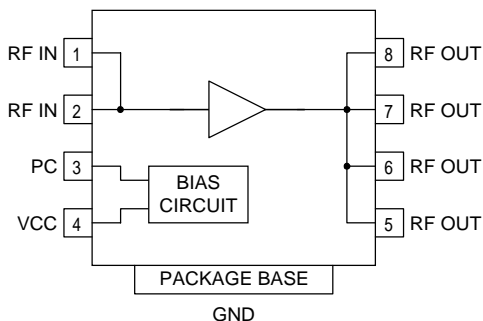

Functional Block Diagram

Ordering Information

- RF2125 High Power Linear Amplifier
 RF2125 PCBA Fully Assembled Evaluation Board

RF Micro Devices, Inc.
7625 Thorndike Road
Greensboro, NC 27409, USA

Tel (336) 664 1233
Fax (336) 664 0454
<http://www.rfmd.com>

Absolute Maximum Ratings

Parameter	Rating	Unit
Supply Voltage (V_{CC})	-0.5 to +7.5	V_{DC}
Power Control Voltage (V_{PC})	-0.5 to +3.6V	V
DC Supply Current	450	mA
Input RF Power	+20	dBm
Output Load	20:1	
Operating Case Temperature	-40 to +100	°C
Operating Ambient Temperature	-40 to +85	°C
Storage Temperature	-40 to +150	°C



Caution! ESD sensitive device.

RF Micro Devices believes the furnished information is correct and accurate at the time of this printing. However, RF Micro Devices reserves the right to make changes to its products without notice. RF Micro Devices does not assume responsibility for the use of the described product(s).

Parameter	Specification			Unit	Condition
	Min.	Typ.	Max.		
Overall					$T=25^{\circ}\text{C}$, $V_{CC}=6.0\text{V}$, $V_{PC}=3.5\text{V}$, $Z_{LOAD}=12\Omega$, $P_{IN}=0\text{dBm}$, Freq=1895MHz, Idle current=180mA
Frequency Range		1500 to 2200		MHz	
Maximum Output Power		+28.5		dBm	$V_{CC}=3.6\text{V}$, $P_{IN}=+17\text{dBm}$
Maximum Output Power		+29.5		dBm	$V_{CC}=4.8\text{V}$, $P_{IN}=+17\text{dBm}$
Maximum Output Power	+29.5	+30		dBm	$V_{CC}=6.0\text{V}$, $P_{IN}=+17\text{dBm}$
Total Power Added Efficiency		45		%	Maximum output, $V_{CC}=3.6\text{V}$
Total Power Added Efficiency		45		%	Maximum output, $V_{CC}=4.8\text{V}$
Total Power Added Efficiency		45		%	Maximum output, $V_{CC}=6.0\text{V}$
Small-signal Gain		14		dB	
Second Harmonic		-40		dBc	
Third Harmonic		-45		dBc	
Fourth Harmonic		-35		dBc	
Isolation		15		dB	$V_{PC}=0.2\text{V}$
Input VSWR		1.5:1			With external matching network; see application schematic
Two-tone Specification					
Average Two-Tone Power		+27		dBm	PEP-3dB
IM_3	-24	-30		dBc	$P_{OUT}=+24\text{dBm}$ for each tone
IM_5		-35		dBc	$P_{OUT}=+24\text{dBm}$ for each tone
IM_7		-45		dBc	$P_{OUT}=+24\text{dBm}$ for each tone
Power Control					
V_{PC}	1.5	3.3	3.6	V	To obtain 180mA idle current
Power Control "OFF"	0.2	0.5		V	Threshold voltage at device input
Power Supply					
Power Supply voltage		2.7 to 7.5		V	
Supply Current	270	360	410	mA	$P_{OUT}=+30\text{dBm}$, $V_{CC}=6.0\text{V}$
Power Down Current		0.5	10	μA	$V_{PC}=0.2\text{V}$

Pin	Function	Description	Interface Schematic
1	RF IN	RF input. This input is DC coupled, so an external blocking capacitor is required if this pin is connected to a DC path. An optimum match to $50\ \Omega$ is obtained by providing an external series capacitor of $4.3\ \text{pF}$ and then a shunt capacitor of $3.3\ \text{pF}$; see the application schematic. Those values are typical for $1880\ \text{MHz}$; other values may be required for other frequencies.	
2	RF IN	Same as pin 1.	
3	PC	Power control pin. For obtaining maximum performance the voltage on this pin can be used to set correct bias level. In a typical application this is implemented by a feedback loop. The feedback can be based on the actual supply current of the device, i.e., maintaining a fixed current level, or it can be based on the RF output power level to maintain a fixed RF power level (Automatic Level Control loop). A voltage of $0.5\ \text{V}$ or lower brings the part into power down state.	
4	VCC	Power supply pin for the bias circuits. External low frequency bypass capacitors should be connected if no other low frequency decoupling is nearby.	
5	RF OUT	RF output and bias for the output stage. The power supply for the output transistor needs to be supplied to this pin. This can be done through a quarter wave length microstrip line that is RF grounded at the other end, or through an RF inductor that supports the required DC currents. Optimum load impedance is achieved by providing a shunt capacitor of $3.0\ \text{pF}$ and a series capacitor of $3.9\ \text{pF}$; see the application schematic. Those values are typical for $1880\ \text{MHz}$; other values may be required for other frequencies. Since there are several output pins available, which are internally connected, one pin can be used for connecting the bias, another for connecting a (third) harmonic trap filter, and the other pins for the RF output.	
6	RF OUT	Same as pin 5.	
7	RF OUT	Same as pin 5.	
8	RF OUT	Same as pin 5.	
Pkg Base	GND	Ground connection. The backside of the package should be connected to the ground plane through a short path, i.e., vias under the device may be required.	

Application Schematic 1880 MHz

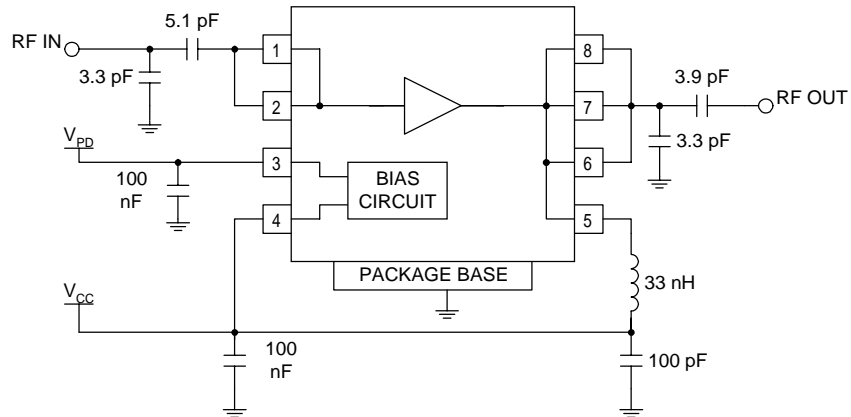

Evaluation Board Schematic 1880MHz

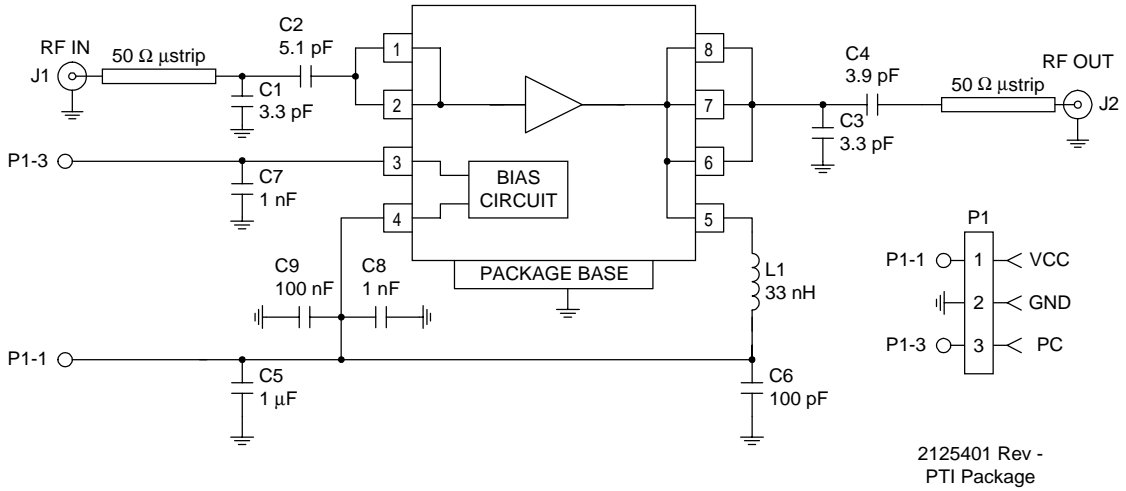

Evaluation Board Layout 1.5" x 1.0"

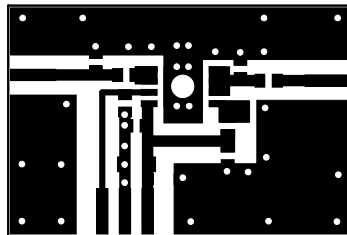
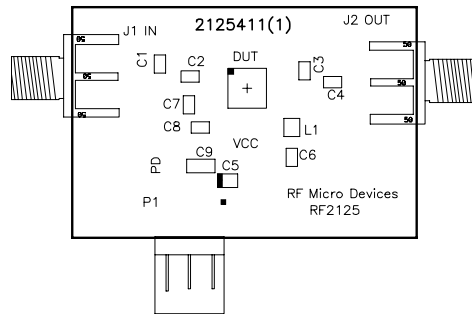

The data below is valid only under small-signal conditions. The device needs to be biased in Class A, with the output power below the 1-dB compression point. For large signal operation this data may be used as a starting point, but further tuning to optimize performance will be required.

Voltage and idle current have only very limited effect on the input and output impedances, hence only one plot is shown, valid for $V_{CC}=5$ to 7V, and $I_{CC}=50$ to 250mA.

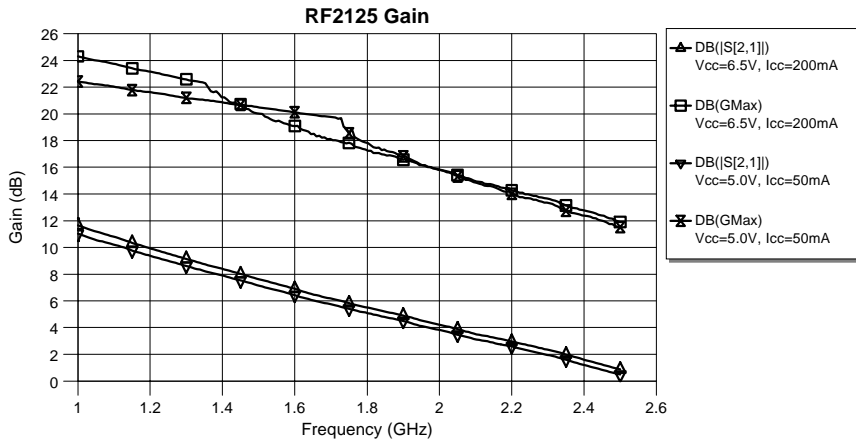

RF2125 Input / Output Impedance, Class A bias

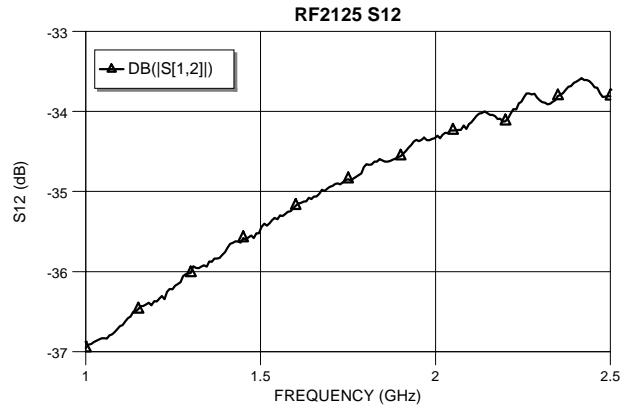
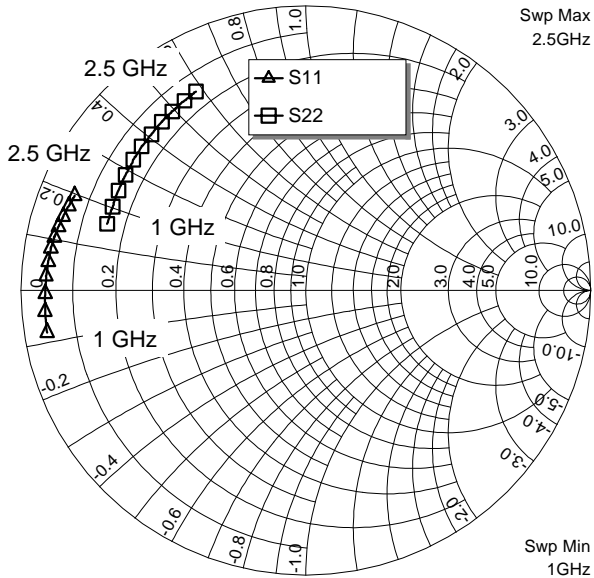

RF2125

2

POWER AMPLIFIERS