

High-Voltage EL Lamp Driver

Ordering Information

Device	Package Options		
	MSOP-8	SO-8	Die
HV826	HV826MG*	HV826LG	HV826X

* Product supplied on 1000 piece carrier tape reels.

Features

- 1.8V to 3.5V operating supply voltage
- DC to AC conversion
- Adjustable output frequency
- Adjustable switch frequency
- Output voltage regulation
- Enable/disable function

Applications

- Mobile cellular phones
- Pagers
- Portable Transceivers
- Remote Control Units
- Calculators

Absolute Maximum Ratings*

Supply Voltage, V_{DD}	-0.5V to +4.5V
Output Voltage, V_{CS}	-0.5V to +120V
Operating Temperature Range	-25° to +85°C
Storage Temperature Range	-65°C to +150°C
MSOP-8 Power Dissipation	250mW
SO-8 Power Dissipation	400mW

Note:

*All voltages are referenced to GND.

General Description

HV826 is a high voltage driver designed for driving EL lamps. The input supply voltage range is from 1.8V to 3.5V. The device uses a single inductor and a minimum number of passive components. The nominal regulated output voltage that is applied to the EL lamp is $\pm 80V$. The chip can be enabled/disabled by connecting the resistor on R_{SW-osc} to V_{DD} /ground.

The HV826 has two internal oscillators, a switching MOSFET, and a high voltage EL lamp driver. The frequency for the switching MOSFET is set by an external resistor connected between the R_{SW-osc} pin and the supply pin V_{DD} . The EL lamp driver frequency is set by an external resistor connected between R_{EL-osc} pin and the V_{DD} pin. An external inductor is connected between the L_x and V_{DD} pins. A 0.01-0.1 μF capacitor is connected between C_s and ground. The EL lamp is connected between V_A and V_B .

The switching MOSFET charges the external inductor and discharges it into the capacitor at C_s . The voltage at C_s will start to increase. Once the voltage at C_s reaches a nominal value of 80V, the switching MOSFET is turned OFF to conserve power. The outputs V_A and V_B are configured as an H bridge and are switching in opposite states to achieve 160V peak-to-peak across the EL lamp.

Pin Configuration

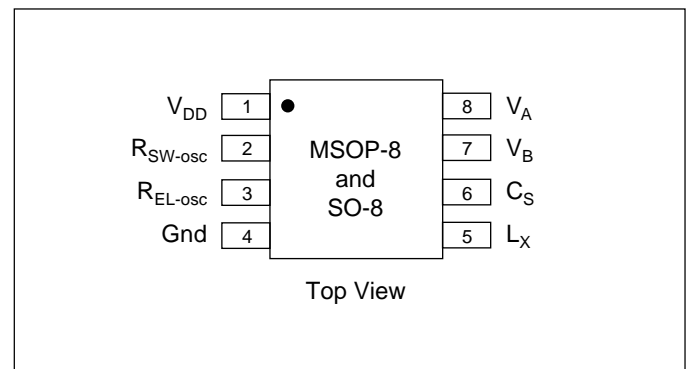

Electrical Characteristics

DC Characteristics (Over recommended operating conditions unless otherwise specified, $T_A=25^\circ\text{C}$)

Symbol	Parameter	Min	Typ	Max	Units	Conditions
$R_{DS(on)}$	On-resistance of switching transistor			7.0	Ω	$I=100\text{mA}$
V_{CS}	Max. output regulation voltage	75	80	85	V	$V_{DD}=1.8\text{V to }3.5\text{V}$
V_{A-B}	Max. of differential output voltage across lamp	150	160	170	V	$V_{DD}=1.8\text{V to }3.5\text{V}$
I_{DDQ}	Quiescent V_{DD} supply current			100	nA	$R_{SW-osc} = \text{Low}$
I_{DD}	Input current going into the V_{DD} pin			150	μA	$V_{DD}=1.8\text{V to }3.5\text{V}$. See Figure 1.
I_{IN}	Input current including inductor current		35	45	mA	$V_{IN}=1.5\text{V}$. See Figure 1.
V_{CS}	Output voltage on V_{CS}	65	70		V	$V_{IN}=1.5\text{V}$. See Figure 1.
f_{EL}	V_{A-B} output drive frequency	300	375	450	Hz	$V_{IN}=1.5\text{V}$. See Figure 1.
f_{SW}	Switching transistor frequency		80		KHz	$V_{IN}=1.5\text{V}$. See Figure 1.
D	Switching transistor duty cycle		88		%	See figure 1.

Recommended Operating Conditions

Symbol	Parameter	Min	Typ	Max	Units	Conditions
V_{DD}	Supply voltage	1.8		3.5	V	
f_{EL}	V_{A-B} output drive frequency	60		1000	KHz	
T_A	Operating temperature	-25		85	$^\circ\text{C}$	

Enable/Disable Function Table

Symbol	Parameter	Min	Typ	Max	Units	Conditions
EN-L	Logic input low voltage	0		0.5	V	$V_{DD}=1.8\text{V to }3.5\text{V}$
EN-H	Logic input high voltage	$V_{DD}-0.5$		V_{DD}	V	$V_{DD}=1.8\text{V to }3.5\text{V}$

Block Diagram

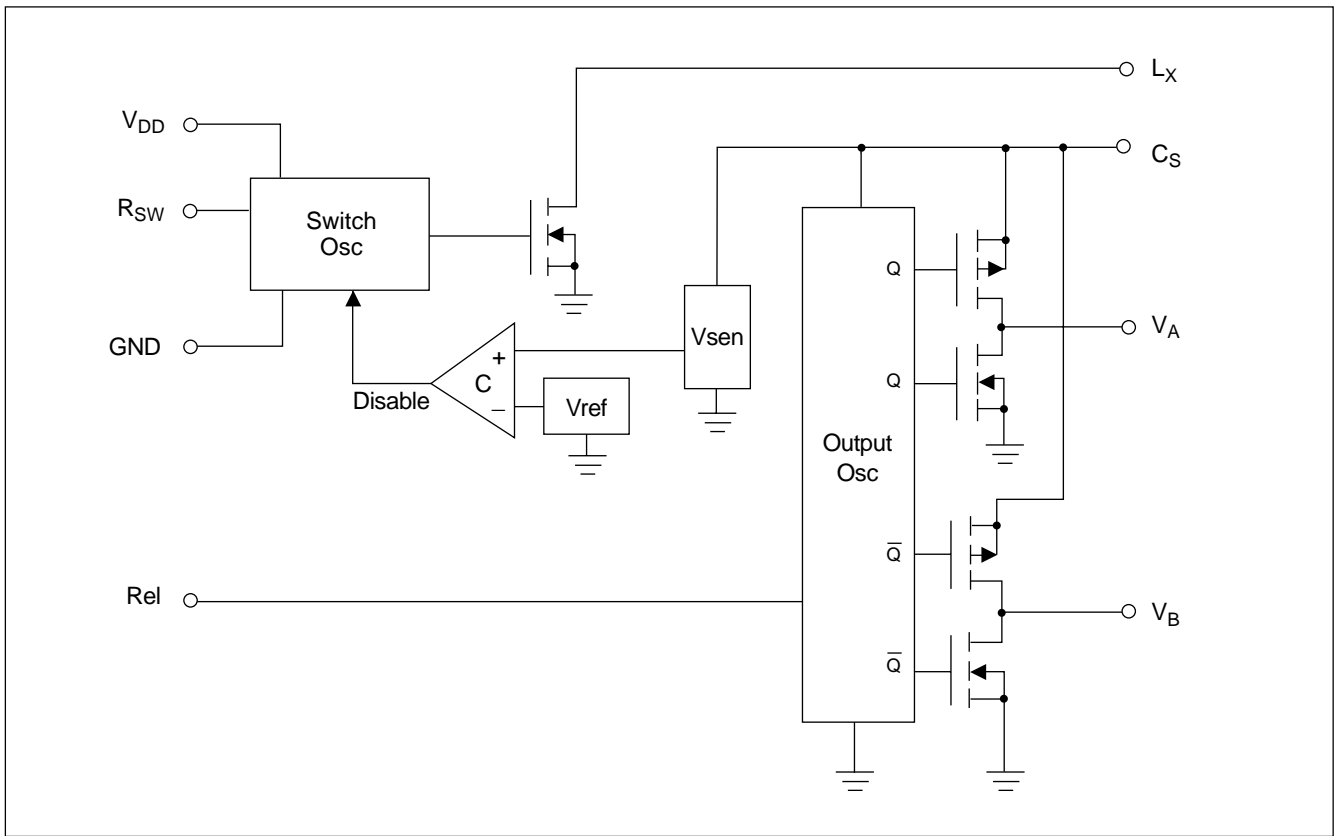

Figure 1: Typical Application

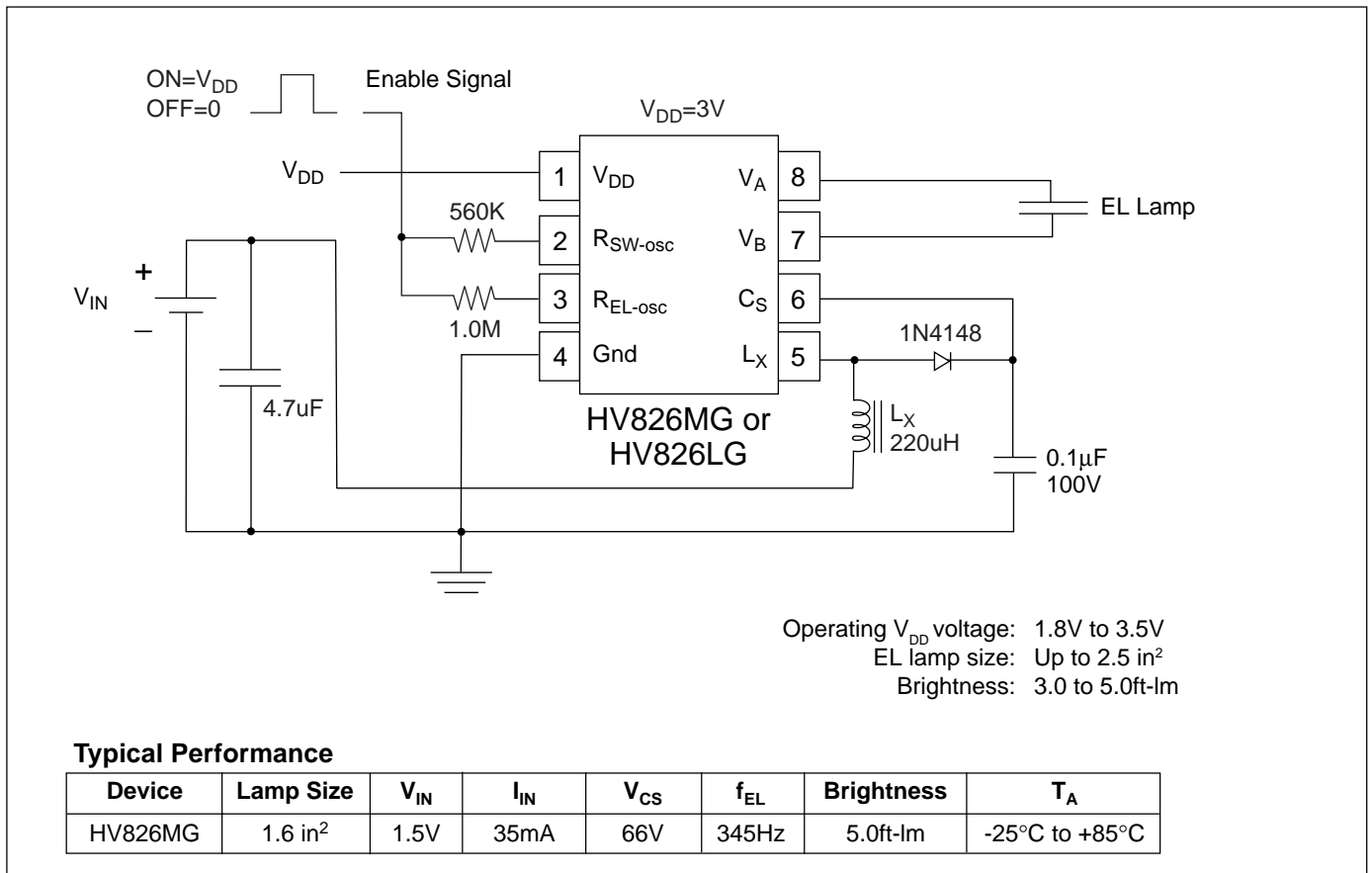

Figure 2: Typical Application

