

RF Components

HHM15 series

Balun Transformers

For Cellular Phone(including Bluetooth)

This small SMD type chip balun transformer is formed using a multi-layer process. This miniaturized product(3.2×1.6mm) has roughly 1/3 the volume of previous product with equivalent characteristics.

FEATURES

- Miniaturized SMD type(L2.0×W1.25×T0.95mm typ.).
- Low insertion loss(Example: 1.0dB max.).

APPLICATIONS

Impedance matching, balanced to unbalanced conversion for mobile communication equipment

TEMPERATURE RANGES

Type	Transformer
Operating	-25 to +75°C
Storage	-40 to +85°C

SHAPES AND DIMENSIONS/CIRCUIT DIAGRAM

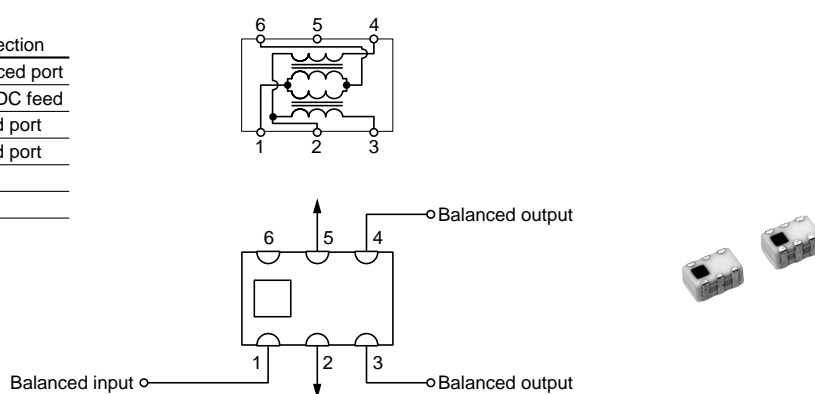
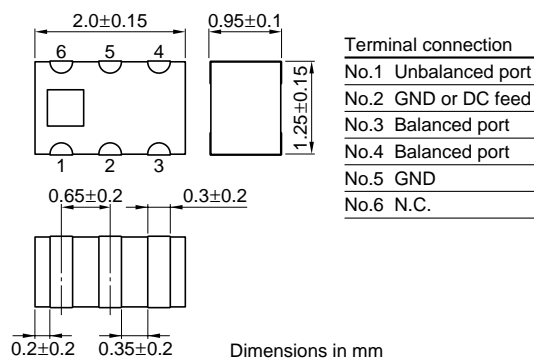

RECOMMENDED PC BOARD PATTERN REFLOW

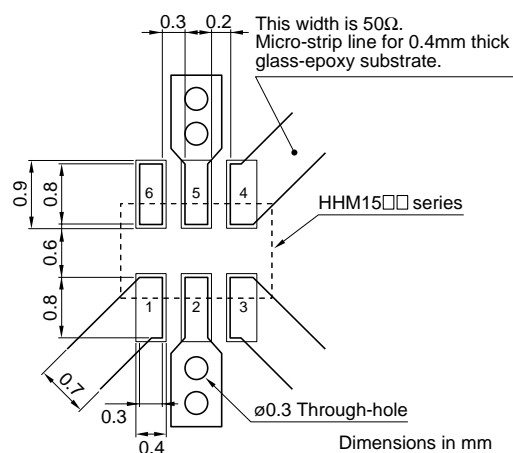

RECOMMENDED REFLOW SOLDERING CONDITIONS

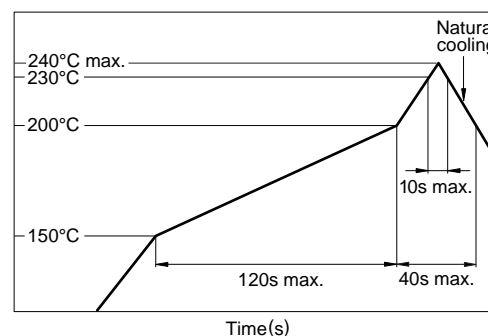

RF Components

HHM15 series

Balun Transformers

For Cellular Phone(including Bluetooth)

APPLICATIONS/ELECTRICAL CHARACTERISTICS(Typical)

Ta=25°C

Part No.	Type	Applications	Frequency (MHz)	Impedance (Ω)		Return loss (dB)min.	Phase imbalance at balanced port (degree)	Amplitude imbalance at balanced port (dB)max.	Insertion loss (dB)
				Unbalanced	Balanced				
HHM1502	Transformer	DCS Lo	1619 to 1705	50	100	12	180 \pm 5	1	0.8
HHM1503		DCS/PCS Tx	1710 to 1910	50	200	10	180 \pm 10	1	1
HHM1504		EGSM Tx	880 to 915	50	150	10	180 \pm 10	1	1
HHM1505		DCS Rx/PCS	1805 to 1990	50	50	10	180 \pm 10	1	0.6
HHM1509		EGSM-DCS Lo	1275 to 1525	50	200	10	180 \pm 10	2	1
HHM1512		DCS Rx	1801 to 1880	50	50	10	180 \pm 5	1	0.9
HHM1513		GSM Rx	925 to 967	50	50	10	180 \pm 5	1	1.3
HHM1517		Bluetooth	2400 to 2500	50	50	10	180 \pm 10	2	1.2
HHM1520		Bluetooth	2400 to 2500	50	100	10	180 \pm 10	2	1
HHM1521		Bluetooth	2400 to 2500	50	200	10	180 \pm 10	2	1

TYPICAL ELECTRICAL CHARACTERISTICS

FREQUENCY CHARACTERISTICS

HHM1504[Unbalance 50 Ω /Balance 150 Ω]

RETURN LOSS

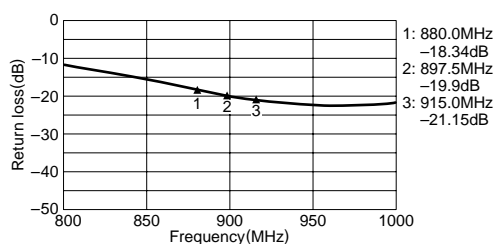

AMPLITUDE BALANCE

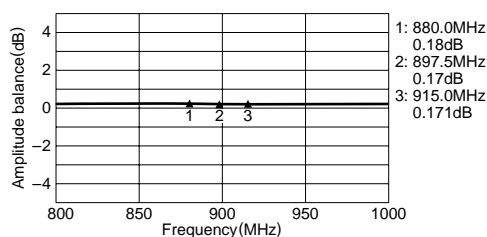

INSERTION LOSS

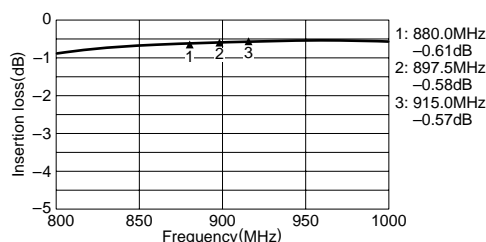

PHASE BALANCE

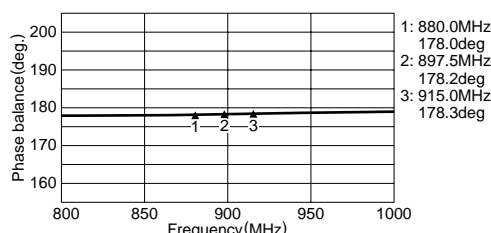

TEST CIRCUIT

PHASE BALANCE AND AMPLITUDE BALANCE

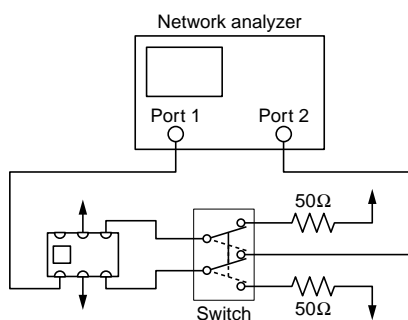

RETURN LOSS AND INSERTION LOSS

