

# MONOLITHIC AMPLIFIERS

50Ω

## BROADBAND DC to 8 GHz

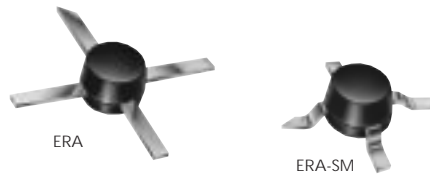

low power, up to +13.5 dBm output

all specifications at 25°C

MODEL NO.	FREQ. GHz $f_c - f_u$	GAIN, dB Typical								MAXIMUM POWER (dBm) at 2 GHz*			DYNAMIC RANGE at 2 GHz*		VSWR (:1) Typ.				ABSO-LUTE MAX. RATING <sup>3</sup>		DC OPERATING POWER <sup>4</sup> at Pin 3			THERMAL RESIS-TANCE	CASE STYLE	CONNEC-TION	PRICE \$	
		over frequency, GHz								Output (1 dB Comp.) Typ.	Input (no dmg) Min.	NF (dB) Typ.	IP3 (dBm) Typ.	In DC-3 GHz	Out 3-f <sub>u</sub> ** DC-3 GHz	I (mA)	P (mW)	Device			θjc Typ. °C/W	Note B						
		0.1	1	2	3	4	6	8	Min. @ 2 GHz									Current	Typ	Min			Max					
ERA-1	DC-8	12.3	12.1	11.8	10.9	9.7	7.9	8.2	9	12.0	10.0	15	4.3	26	1.5	1.8	1.5	1.9	75	330	40	3.4	3.0	4.1	178	VV105	cb	1.37
ERA-2	DC-6	16.2	15.8	15.2	14.4	13.1	11.2	—	13	13.0	11.0	15	4.0	26	1.3	1.4	1.2	1.6	75	330	40	3.4	3.0	4.1	155	VV105	cb	1.52
ERA-3	DC-3	22.1	21.0	18.7	16.8	—	—	—	16	12.5	9.0	13	3.5	25	1.5	—	1.4	—	75	330	35	3.2	3.0	4.1	154	VV105	cb	1.67
ERA-1SM	DC-8	12.3	12.1	11.8	10.9	9.7	7.9	8.2	9	12.0	10.0	15	4.3	26	1.5	1.8	1.5	1.9	75	330	40	3.4	3.0	4.1	183	WW107	cb	1.42
NEW ERA-21SM	DC-8	14.2	13.9	13.2	12.2	10.8	8.7	8.9	11.2	12.6	10.6	15	4.7	26	1.1	1.4	1.3	1.9	75	330	40	3.5	3.0	4.1	194	WW107	cb	1.57
ERA-2SM	DC-6	16.2	15.8	15.2	14.4	13.1	11.2	—	13	13.0	11.0	15	4.0	26	1.3	1.4	1.2	1.6	75	330	40	3.4	3.0	4.1	160	WW107	cb	1.57
NEW ERA-33SM	DC-3	19.3	18.7	17.4	15.9	—	—	—	15	13.5	11.5	13	3.9	28.5	1.6	—	1.25	—	75	330	40	4.3	3.8	4.8	140	WW107	cb	1.72
ERA-3SM	DC-3	22.1	21.0	18.7	16.8	—	—	—	16	12.5	9.0	13	3.5	25	1.5	—	1.4	—	75	330	35	3.2	3.0	4.1	159	WW107	cb	1.72
NEW ERA-8SM	DC-2	31.5	25.0	19.0	15.0	12.0	—	—	17	12.5	—	13	3.1	25	1.4	1.8	1.8	2.2	65	250	36	3.7	3.2	4.2	140	WW107	cb	1.22

see suggested PCB layout PL-075 for ERA models

### features

- low thermal resistance
- miniature microwave amplifier
- frequency range, DC to 8 GHz, usable to 10 GHz
- up to 18.4 dBm typ. (16.5 dBm min) output power

### absolute maximum ratings

operating temperature: -45°C to 85°C  
storage temperature: -65° to 150°C

### model identification

Model marking (see note below)

ERA-1, ERA-1SM	1
ERA-2, ERA-2SM	2
ERA-21SM	21
ERA-3, ERA-3SM	3
ERA-33SM	33
ERA-4, ERA-4SM	4
ERA-5, ERA-5SM	5
ERA-50SM	50
ERA-51SM	51
ERA-5XSM	5X
ERA-6, ERA-6SM	6
ERA-8SM	E8

Note: Prefix letter (optional) designates assembly location. Suffix letters (optional) are for wafer identification.

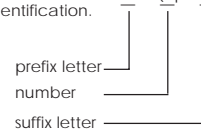

### NOTES:

- ◆ Aqueous washable
- \* at 1 GHz for ERA-4,5,6, 4SM, 5SM, 50SM, 51SM, 6SM, 8SM.
- \*\*  $f_u$  is the upper frequency limit for each model as shown in the table; for ERA-8SM VSWR (In & Out) is specified at DC-1GHz & 1-4 GHz.
- \*\*\* Gain and VSWR are specified at 1.5 GHz.
- ⊛ Low frequency cutoff determined by external coupling capacitors.
- A. Environmental specifications and re-flow soldering information available in General Information Section.
- B. Units are non-hermetic unless otherwise noted. For details on case dimensions & finishes see "Case Styles & Outline Drawings".
- C. Prices and Specifications subject to change without notice.
- D. For Quality Control Procedures see Table of Contents, Section 0, "Mini-Circuits Guarantees Quality" article. For Environmental Specifications see Amplifier Selection Guide.
- 1. Model number designated by alphanumeric code marking.
- 2. ERA-SM models available on tape and reel.
- 3. Permanent damage may occur if any of these limits are exceeded. These ratings are not intended for continuous normal operation.
- 4. Supply voltage must be connected to pin 3 through a bias resistor in order to prevent damage. See "Biasing MMIC Amplifiers" in minicircuits.com/application.html. Reliability predictions are applicable at specified current & normal operating conditions.

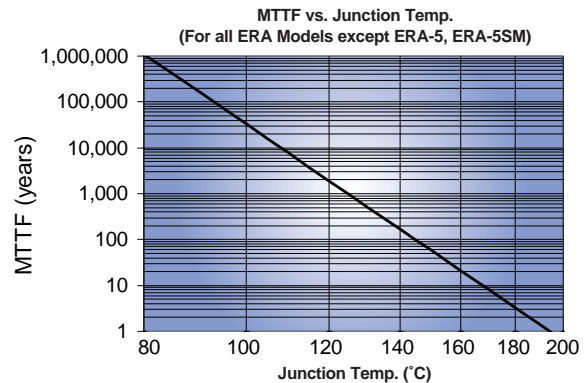

# Drop-In & Surface Mount

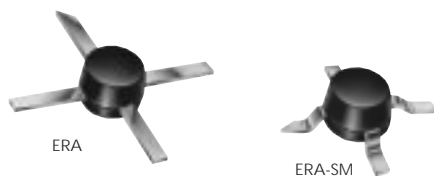

medium power, up to +18.4 dBm output

all specifications at 25°C

MODEL NO.	FREQ. GHz $f_c - f_u$	GAIN, dB Typical							MAXIMUM POWER (dBm) at 2 GHz*			DYNAMIC RANGE at 2 GHz*		VSWR (-1) Typ.				ABSO-LUTE MAX. RATING <sup>3</sup> I (mA) P (mW)	DC OPERATING POWER <sup>4</sup> at Pin 3				THERMAL RESISTANCE $\theta_{jc}$ Typ. °C/W	CASE STYLE Note B	CONNECTION	PRICE \$ Qty. (30)		
		over frequency, GHz							Output (1 dB Comp.) Typ. Min.	Input (no dmg) Typ. Min.	NF (dB) Typ.	IP3 (dBm) Typ.	In DC-3 GHz	Out 3-f <sub>u</sub> ** DC-3-f <sub>u</sub> ** GHz	I	P	Device Volt. Min Max											
		0.1	1	2	3	4	6	8									Min. @ 2 GHz		Typ.	Typ.	Typ.	Typ.					Typ.	Typ.
ERA-6	DC-4	12.6	12.5	12.2	11.7	11.3	—	—	10.5	17.9	16	20	4.5	36	1.3	1.2	1.6	1.8	120	650	70	5.0	4.6	5.6	170	VV105	cb	3.85
ERA-4	DC-4	14.3	14.0	13.4	12.7	11.8	—	—	11	17.3	15	20	4.2	34	1.2	1.2	1.3	1.8	120	650	65	4.5	4.2	5.5	163	VV105	cb	3.85
ERA-5	DC-4	20.2	19.5	18.5	17.3	16.2	—	—	16	18.4	16.5	13	4.3	32.5	1.3	1.3	1.2	1.3	120	650	65	4.9	4.2	5.5	278	VV105	cb	3.85
ERA-6SM	DC-4	12.6	12.5	12.2	11.7	11.3	—	—	10.5	17.9	16	20	4.5	36	1.3	1.2	1.6	1.8	120	650	70	5.0	4.6	5.6	175	WW107	cb	3.90
ERA-4SM	DC-4	14.3	14.0	13.4	12.7	11.8	—	—	11	17.3	15	20	4.2	34	1.2	1.2	1.3	1.8	120	650	65	4.5	4.2	5.5	168	WW107	cb	3.90
NEW ERA-5XSM	DC-4	20.5	19.5	17.6	15.5	13.7	—	—	16	17.8	16.5	13	3.5	33	1.2	1.3	1.2	1.4	120	650	65	4.9	4.2	5.5	133	WW107	cb	1.69
NEW ERA-51SM	DC-4	18.0	17.4	16.1	14.8	12.5	—	—	14	18.1	16.5	13	4.1	33	1.1	1.2	1.2	1.9	120	650	65	4.5	4.2	5.5	154	WW107	cb	3.90
NEW ERA-5SM	DC-4	20.2	19.5	18.5	17.3	16.2	—	—	16	18.4	16.5	13	4.3	32.5	1.3	1.3	1.2	1.3	120	650	65	4.9	4.2	5.5	283	WW107	cb	3.90
ERA-50SM**	DC-1.5	20.7	19.4	18.3	—	—	—	—	16	17.2	16.0	13	3.5	32.5	1.3	—	1.2	—	120	650	60	4.4	4.0	4.9	177	WW107	cb	2.95

see suggested PCB layout PL-075 for ERA models

## typical biasing configuration

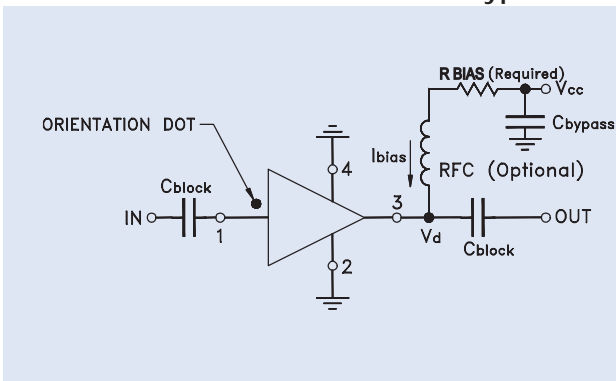

R BIAS										
"1%" Resistor Values (ohms) for Optimum Biasing of ERA models										
Vcc	ERA-1, -1SM	ERA-2, -2SM	ERA-21SM	ERA-3, -3SM	ERA-33SM	ERA-4, -4SM	ERA-5, -5SM, -5XSM	ERA-50SM, -51SM	ERA-6, -6SM	ERA-8SM
7	90.9	88.7	88.7	107	69.8	38.3	33.2	40.2	30.1	88.7
8	113	113	113	133	93.1	52.3	48.7	53.6	43.2	118
9	137	137	137	162	115	66.5	63.4	68.1	56.2	143
10	162	162	162	191	140	80.6	78.7	82.5	69.8	174
11	187	187	187	221	165	95.3	95.3	97.6	84.5	200
12	215	215	210	249	191	110	110	113	97.6	226
13	237	237	237	280	215	127	124	127	113	255
14	261	261	261	309	243	143	140	143	127	280
15	287	287	287	340	267	158	158	158	140	309
16	309	316	316	365	287	174	174	174	154	340
17	332	340	340	392	316	187	187	191	169	365
18	357	365	365	422	340	205	205	205	182	392
19	383	392	392	453	365	221	221	221	196	422
20	412	412	412	475	392	237	232	237	210	453

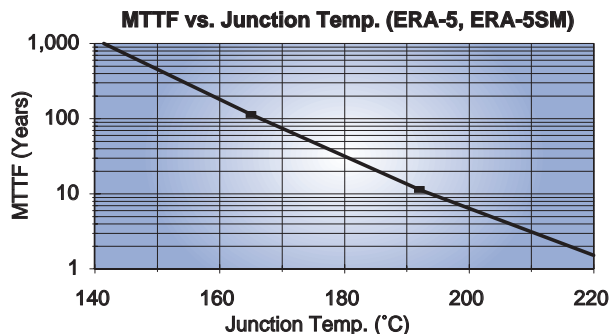

**NSN GUIDE**

MCL NO.	NSN
ERA-1SM	5962-01-459-9075
ERA-4SM	5962-01-459-7410
ERA-5SM	5962-01-459-9314

**pin connections**

PORT	cb
RF IN	1
RF OUT	3
DC	3
CASE GND	2,4
NOT USED	—
DEMO BOARD	ERA-TB

## designers kits available

KIT NO.	Model Type	No. of Units in Kit	Description	Price \$ per kit
K1-ERA	ERA	30	10 of each 1,2,3	49.95
K2-ERA	ERA	20	10 of each 4,5	69.95
K1-ERASM	ERA-SM	30	10 of each 1SM, 2SM,3SM	49.95
K2-ERASM	ERA-SM	20	10 of each 4SM, 5SM	69.95
K3-ERASM	ERA-SM	30	10 of each 4SM, 5SM, 6SM	99.95