

## Introduction

Every wireless system is composed of the following five components:

- Data encoder
- Baseband-to-RF transducer
- Antenna system
- RF-to-baseband transducer
- Data decoder

This is illustrated in the block diagram of Figure 1.

The MICRF001 UHF receiver IC, developed by Micrel, provides a low-cost solution for the RF-to-baseband transducer in Figure 1, for applications in the 300MHz to 440MHz frequency band. Integrated and discrete solutions also readily exist for the data encoder/decoder functions and for the baseband-to-RF transducer (commonly called the transmitter).

Undeniably, of all the elements in Figure 1, the antenna system is the most difficult to design and optimize. There are several reasons for this. First, many designers lack sufficient working experience with antennas to gain an intuitive feel, especially in low-power, low-cost applications. Antenna measurement and characterization requires sophisticated and expensive test equipment, which may not be readily available. Also, antenna analysis often relies on simplifying assumptions, which may not hold in all cases, and often leads to measurement inconsistency.

Reading this application note will not make one an antenna expert. Antenna design and optimization is too complex and driven by variables which are often beyond the designer's control. To add insult to injury, the entire problem is further complicated if the antenna is located remotely from the receiver through a transmission line. In these cases impedance matching networks may need to be designed.

Fortunately, the problem of selecting an appropriate antenna is not as overwhelming as it seems. Most low power remote-control wireless applications are sensitive not only to range, but to cost and packaging constraints as well. And the most appropriate antennas for these applications are fairly simple structures. They can be easily characterized and compared

using some basic terms. The problem is further simplified because antenna systems in these applications are usually connected directly to the transmitting and receiving units.

It has been determined that the best overall antenna for such applications is simply a "piece of wire". Certainly no antenna is less expensive, especially when the "wire" is built into the electronic circuit board. It only remains then to choose the form factor of this "wire." By this we mean whether the wire is straight, coil, or a single loop. In many instances even the form factor is dictated by product packaging constraints. For example, when the package must be very small and completely enclosed, a coil or loop will be the preferred choice, assuming the range constraint can also be met.

The MICRF001 UHF receiver is designed to be connected directly to the antennas described above and achieve range performance adequate for most applications. Other high-performance antennas exist, but cost constraints prohibit their consideration in all but the highest-performance applications. This application note will only discuss relative performance characteristics of the three most popular antennas—straight wire (monopole), (helical) coil, and loop—in the context of what is generally important to the user (range performance, size, and ease of design). For a more thorough treatment of the theory, consult one or more of the references in the bibliography.

The intent of this application note is to provide the user with sufficient guidance to develop an antenna system for the MICRF001—simply, quickly, and with a reasonable degree of performance—especially for inexperienced users. If after applying the concepts discussed here, range performance still is not adequate, further antenna optimization may be attempted; however, one should not expect significant range improvements to come from these further efforts. Antenna system optimization is closely linked to the "law of diminishing returns." This simply means that one can derive most of the optimum antenna performance with a modest amount of effort, and some simple guidelines. Beyond this point, incremental improvements become increasingly costly, and yield only marginal range benefit.

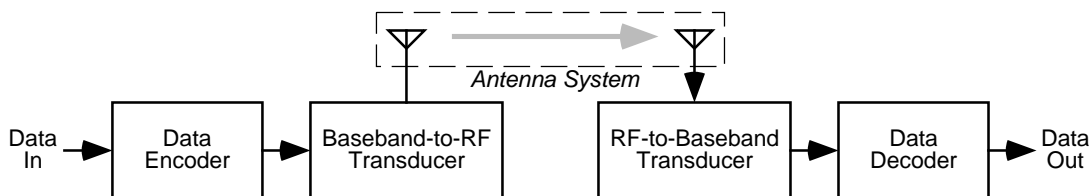

**Figure 1. Wireless Communication System—Simplified Block Diagram**

Perhaps a better approach, where significant further range improvement is needed, is to consider other more efficient antenna types, assuming all other constraints (for example, packaging) can be met. Discussion of such other solutions is beyond the scope of this application note.

Each section of this application note is self-contained, with significant passages italicized. This should help the reader to quickly identify and digest the most important passages in each section without getting bogged down in unwanted detail.

## Antenna Characteristics

Before discussing individual antenna types, it may help the reader to understand basic characteristics common to all antennas. However, this section is not required reading for anyone who simply wants to quickly select and apply an antenna to the MICRF001. Those individuals should read "Comparison of Antenna Types" describing the desired antenna.

### Reciprocity Theorem of Antennas

The "reciprocal nature of antennas" means that the electromagnetic characteristics of a transmit antenna are equivalent to those of a receive antenna, assuming the antennas are identical in form-factor and orientation. A more general theorem known as the "reciprocity theorem of antennas" is as follows<sup>1</sup>: If a voltage is applied to the terminals of antenna *A*, and the current is measured at the terminals of another antenna *B*, then an equal current (in both amplitude and phase) will be obtained at the terminals of antenna *A* if the same voltage is applied to the terminals of antenna *B*. ***This simply means that any antenna can function equally as well as a transmit antenna or receive antenna.***

### Radiation Pattern and Orientation Effects

Every antenna exhibits its own unique energy profile in the 3-dimensional space around the antenna. This 3-dimensional energy profile is called the antenna's radiation pattern. These patterns are derived theoretically, assuming a uniform, sinusoidal current distribution in the antenna, and that the antenna is located in free-space away from other objects and ground, unless otherwise stated. The real radiation pattern will then vary from the theoretical pattern as these assumptions break down.

As an example, the radiation patterns for three different wave lengths of linear dipole antenna are illustrated in Figures 2a–2c. The angle of view in Figure 2a–2c. is from the side of a vertically oriented straight wire.

The patterns indicate relative response intensity as a function of (polar) angle in the X-Y axis (the "plane of the paper" X-axis oriented horizontally). Since these are only 2-dimensional figures, the intensity in the Z-direction (the direction "coming out of the paper" when the X-axis is oriented horizontally) is not shown. It should be understood that the field pattern wraps around the antenna in the X-Z plane to form a torus pattern.

These patterns are made up of lobes. Peaks are simply lobe maximums, and nulls are simply lobe minimums. In Figures 2a and 2b, only a single lobe exists, while the pattern is multi-

lobed in Figure 2c. Notice also that the radiation pattern in Figure 2b is more highly directive than that of Figure 2a. Directivity is another characteristic of antennas, which the reader may investigate further through the references.

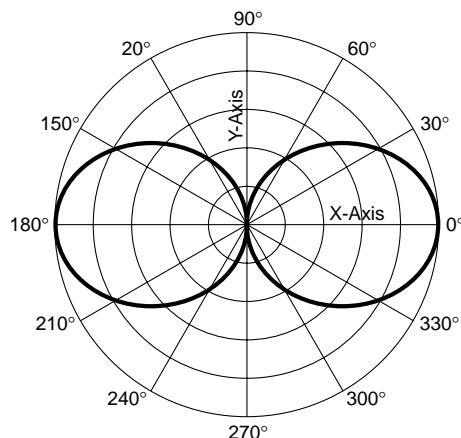

Figure 2a. Half-Wave ( $\frac{1}{2}\lambda$ ) Dipole Radiation Pattern

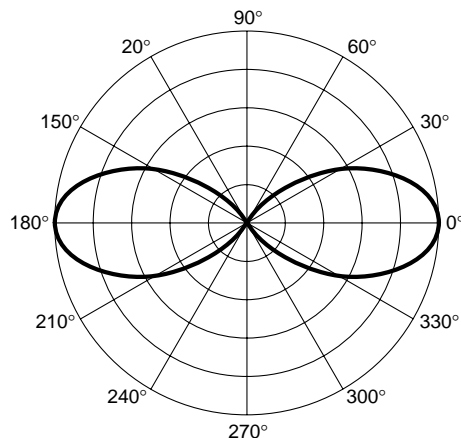

Figure 2b. Full-Wave ( $1\lambda$ ) Dipole Radiation Pattern

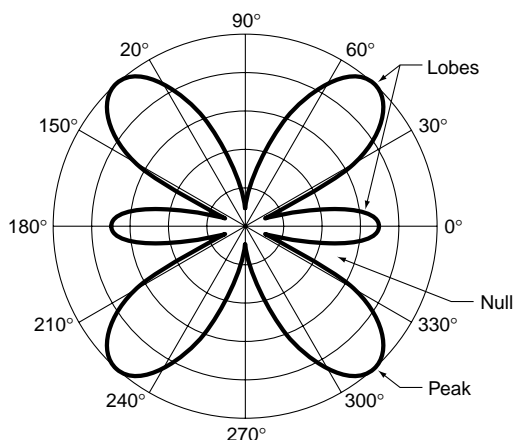

Figure 2c.  $1\frac{1}{2}\lambda$  Dipole Radiation Pattern

This example also demonstrates an antenna radiation pattern's dependence on length. Dipole antenna pattern is fundamentally determined by antenna length, although this is not true for all antenna types. The multilobe response in Figure 2c comes about from the fact that the antenna is longer than 1 wavelength of the operating frequency, which elicits additional constructive and destructive interference of the energy emanating from the antenna in 3-dimensional space. One

further observation is that, for the dipole antenna, no energy emanates from the ends of the antenna.

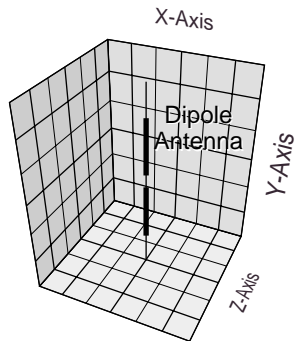

Figure 2d. Typical Dipole Antenna

It should be obvious that two antennas (one transmitting, and the other receiving), whose orientations are such that the lobe maximums face one another, are optimally aligned. Thus one would not normally choose to orient a transmit antenna vertically and receive antenna horizontally in the same plane, since the receive antenna would only pick up a small amount of the energy delivered into the 3-dimensional space around the transmit antenna. This is illustrated in Figure 3a. However, one could simply turn the receive antenna so that both antennas are oriented in the same (vertical) direction, and the antenna would be optimally aligned. This is illustrated in Figure 3b.

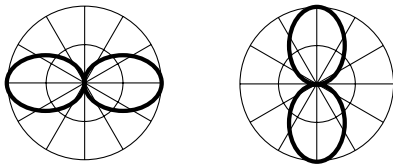

Figure 3a. Misaligned Antenna Radiation Patterns

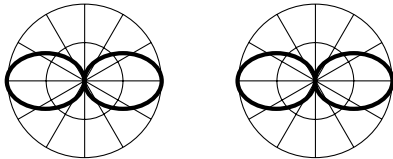

Figure 3b. Fully-Aligned Antenna Radiation Patterns

**Antenna radiation pattern misalignment is a problem that exists in just about every system application. These orientation effects manifest themselves as system range variations and are usually best understood through experimentation. Many times, the user does not have the luxury to optimize antenna orientation, due to packaging constraints, for example. The system designer should try to improve the orientation characteristics as much as possible, but expect application-dependent range variations to occur.**

**Antenna Gain**

For the sake of completeness we shall define antenna gain. The concept is not, strictly speaking, so important, but defines antenna radiation performance relative to a reference antenna.

The reference antenna may be any antenna type arbitrarily chosen by the user. Performance of the antenna under consideration can then be compared with the reference

antenna through the concept of gain. A half-wave dipole antenna is commonly used. Another common reference antenna is called an isotropic radiator. This is an idealized, lossless antenna that radiates equally well in all directions. These two antennas are described analytically in *Reference Data for Radio Engineers*<sup>2</sup>, Chapter 27. Antenna gain is then defined as:

$$\text{gain} = \frac{\text{max. radiation intensity}_{\text{Evaluation Antenna}}}{\text{max. radiation intensity}_{\text{Reference Antenna}}}$$

provided the input power is the same for the reference antenna and the antenna under evaluation.

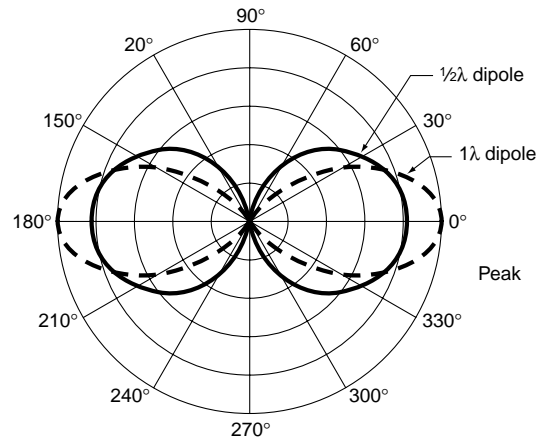

Figure 4. Antenna Gain and Directivity

**Antenna Polarization**

Antenna polarization is a characterization of the directional behavior of the electric vector of the electromagnetic (EM) wave emanating from the antenna. Figures 5a–5d illustrates three types of polarization: linear, elliptic, and circular. These names refer to the figure (line, circle, or ellipse) traced out by the tip of the electric vector as it travels through space. Linear polarization further breaks down into horizontal and vertical polarization, depending on whether the antenna is oriented horizontally or vertically. Polarization characteristics vary with antenna type. For example, linear antennas like monopoles, exhibit linear polarization, while helical antennas are fundamentally circularly polarized. **Ideally, transmit and receive antennas should exhibit compatible polarization for optimum performance. However, as with orientation, this may not always be possible due to other system or packaging constraints. Once again, the designer should try to mitigate this problem as much as possible, but expect range variations to occur.**

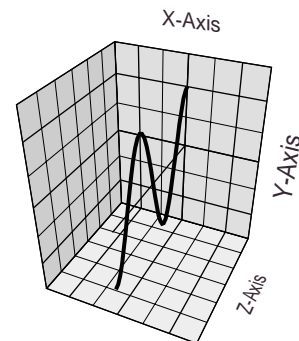

Figure 5a. Linear (Vertical) Polarization

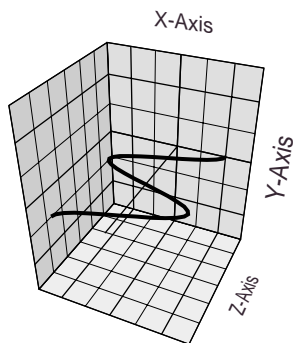

Figure 5b. Linear (Horizontal) Polarization

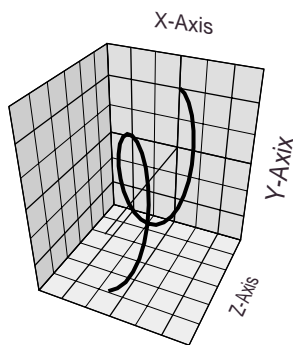

Figure 5c. Elliptical Polarization

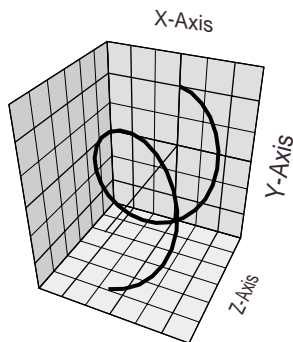

Figure 5d. Circular Polarization

### Antenna Radiation Resistance

An antenna's radiation resistance is a measure of its ability to radiate an applied signal into space, or to receive a signal from space. To calculate the radiation resistance, the antenna is assumed to be lossless. Then, for a given applied signal, the total radiated power ( $P$ ) is calculated or measured, along with the current ( $I$ ) in the antenna. Using the equation

$$P = I^2 \times R$$

where:

$P$  = total radiated power (W)

$I$  = rms antenna current (A)

$R_R$  = antenna radiation resistance ( $\Omega$ )

we associate the radiated power with a radiation "resistance"  $R_R$ . The radiation resistance is not a real (dissipative) resistance, but a measure of the power radiated into free-space for a given input current. The important observation about Radiation resistance is that, for a given current into the antenna, as radiation resistance increases, so does the antenna's efficiency. It will be established later that, in general, larger antennas are more effective "signal collectors," and also exhibit higher radiation resistance than smaller antennas.

This implies that antenna size should be maximized to the extent possible. Antenna size is generally not so important for the transmitters in these low-power applications, since regulatory agencies usually limit the allowable effective radiated power or field strength. It is assumed the signal current could be increased, no matter what the radiation resistance (that is, increase current to offset antenna inefficiency). However, due to the reciprocity theorem of antennas, higher radiation resistance is desirable at the receive antenna since efficiency is important there, so the system designer should maximize this parameter to the extent possible at the receiver.

### Antenna (Terminal) Impedance

The impedance looking into the terminals of an antenna is usually only important for signal power matching into a transmission line (see "Impedance Matching"). Terminal impedance is generally composed of a (real) resistance term plus a reactive term. For an antenna whose radiative losses are much greater than its resistive losses, the resistive term is called the antenna's radiation resistance, previously described.

If the antenna is small and placed close to the input pin of the MICRF001, as is most often the case, the entire structure can be treated as a lumped, rather than distributed, circuit. In this case, impedance matching the antenna to the input of the IC will yield little improvement in range.

If the antenna is located away from the IC, the antenna should be coupled to the IC via a transmission line. In this case, the antenna impedance must be known, so that it can be matched into the characteristic impedance of the transmission line. This requires a matching circuit at the antenna-transmission line interface. A similar circuit is necessary to match the transmission line to the input of the MICRF001. These additional matching networks are only required when the antenna is located away from the input pin of the IC. This subject is further discussed in "Impedance Matching".

### Antenna Resonance and Tuning

An antenna is defined as resonant if its terminal impedance is equal to its radiation resistance. This is equivalent to saying that the terminal impedance contains no reactive impedance component. Since the antenna impedance equals the radiation resistance at resonance, it can be said that the antenna is operating at maximum radiating (or receiving) efficiency.

***An antenna may be "tuned to resonance" at a given frequency by incrementally adjusting the length or form factor of the antenna structure. The antenna will be detuned by placing it in the vicinity of other metallic objects (which introduces parasitic capacitance to the antenna). The antenna's radiation pattern will also be modified by proximity to such objects. When tuning and measuring an antenna system, it is important that the antenna be in its normally deployed state to account for these parasitics. Otherwise, avoid placing the antenna close to other metallic components.***

### Antenna Bandwidth

As one might expect, an antenna's characteristics are valid over only a finite bandwidth. For narrow-band transmitters, commonly used with the MICRF001, bandwidth of commonly used antennas is not an issue. Instances where bandwidth

might be important are where the MICRF001 is used to receive one of several channelized frequencies and the frequencies are spaced widely. It is difficult to quantize bandwidth, since the amount that the antenna characteristics can vary from resonance, is application dependent.

### Ground-Plane Effect on Antenna Performance

***The presence or absence of a ground plane and the need for a ground plane with an antenna is commonly misunderstood. Unless otherwise stated, antenna characteristics are generally derived by assuming the antenna to be in free-space, without any ground plane. (The rare exception to this is the monopole, as introduction of a perfect ground plan allows the monopole to be easily resolved to, and analyzed as, a dipole.) In the absence of a ground plane, the most important characteristics, antenna pattern and terminal impedance, can be determined. When a ground plane is brought into the vicinity of the antenna, these characteristics can be altered, in a manner that may or may not improve system (range) performance***

Antennas in the presence of a ground plane are generally analyzed by the method of images. This approach removes the ground from the analysis, and places an image antenna in space at the appropriate dimensions to mimic the signal reflection associated with the ground plane. The image is not a real antenna at all, but simply a mathematical construct to account for the ground plane signal reflection.

One often sees it stated that the antenna must be located above a "good" ground plane. "Good" usually refers here to a ground plane that is sufficiently large and conductive to allow prediction of the antenna's characteristics with only a small error to a (theoretical) infinite, perfectly conducting plane. This is not strictly necessary. Even without a good ground plane, the antenna will still radiate, but with a pattern and impedance different than if the antenna were above a good ground plane. The best way to think of the ground plane is as an energy reflector from the antenna itself, which, depending on the distance from ground plane to antenna, sets up constructive and destructive interference of signal in space which alters the antenna pattern. The terminal impedance is altered due to the parasitic capacitance from antenna to ground plane. A good description of all this may be found in *Antennas*<sup>1</sup>, Sections 11.7 and 11.8.

***For applications where one has the luxury to use or not use a ground plane, the choice is not particularly clear. If, by using a ground plane, the modified antenna pattern, directionality, and terminal impedance yields the best system performance, then it should be used. Otherwise it should not. For applications where a ground plane must exist, or where no good ground plane can be allowed, the antenna should be optimized for that particular condition. Finally, there is no reason an adequate antenna cannot be constructed, even if there is no good ground plane to work against.***

### Antenna Types

It is beneficial for users to appreciate how the three antenna types (monopole, helical, loop) compare in general terms before getting too involved in the theory surrounding each

antenna type. This section contains rule-of-thumb information which applies generally. However, relative performances can be modulated by such variables as antenna length, orientation, and location to ground plane or parasitics. For this comparison, the monopole is assumed to be a quarter-wavelength long.

Parameter	Loop	Helical	Monopole
Design Simplicity	3	2	1
Range	3	2	1
Size	2	1	3
Parasitic Immunity	1	2	3
Overall Performance	3	2	1
Key: 1 = best relative performance 3 = worst relative performance			

**Table 1. Antenna Performance Summary**

***Monopole antennas are physically larger structures intended for applications which demand the best range. Monopole antennas are also by far the easiest antennas to design and apply.*** Monopoles can be a single straight wire protruding from PCB (the printed circuit board) or may be a (metal) trace built into the PCB (which can lower costs by removing another assembly step). Often, straight wire monopole antennas protrude from the housing assembly, simply due to their size (for example, a 315MHz quarter-wave monopole is 8.9 inches long). Inductively loaded monopoles are available which provide similar performance in a smaller length, but at higher cost than a simple piece of wire. Range of monopole antennas is generally up to 100 meters when used with micropower OOK (on-off keyed) transmitters.

***Small helical antennas are a good compromise, especially where small size is important. The resulting assembly generally can be completely enclosed, and made quite compact. Helical antennas are more difficult to set up and optimize than monopoles since the antenna's characteristics are strongly influenced by coil diameter and compactness of turns along the axial dimension.*** Further, small helical antennas are used in what is commonly called the radial mode of emission, which is not treated in the literature as thoroughly as axial mode operation of large helical antennas<sup>1</sup>. Range is generally up to 60 meters when used with micropower OOK transmitters.

***Loop antennas provide the poorest range of the three antennas under consideration, generally up to 30 meters when used with micropower OOK transmitters. Size is not particularly attractive, but is smaller than a quarter-wave monopole. Loop antennas can be rugged and low cost when the antenna is completely integrated into the PCB.*** An alternative consideration is to use a less-than-quarter-wave monopole built into the PCB rather than a loop antenna. Such an antenna might provide the advantages of a loop (ruggedness, cost) while providing better range.

*It is convenient to think of the helical antenna as the general structure, and that the monopole and loop antennas are simply degenerate forms of the helical. For example, completely stretching out the helical antenna yields a monopole, and compressing a helical antenna inwards yields a loop*

antenna. So it is not unexpected that the helical performance is generally between the two extremes of monopole and loop antenna.

**Monopole Antennas**

Monopole antennas are commonly used in applications with the MICRF001 where range is important. These antennas are also very easy to design and tune simply by slight changes in length. It is assumed the antenna is a quarter-wavelength long, which is typical of monopole antennas in the UHF band.

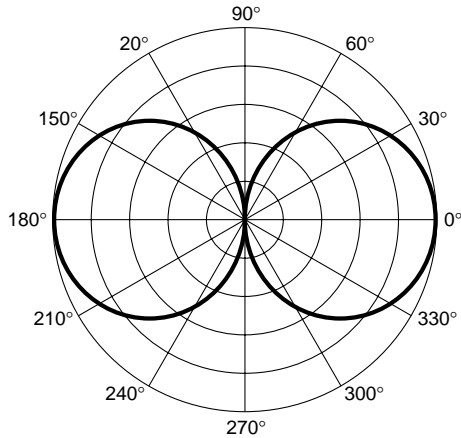

**Figure 6. 0.25λ Monopole Over Ground Plane**

Figure 6 illustrates the radiation pattern of a quarter-wavelength monopole above a ground plane. The radiation is linearly polarized, either horizontally or vertically, depending on antenna orientation. Radiation resistance of a quarter-wave monopole is approximately 37Ω, and does not vary much with presence or absence of ground plane<sup>3</sup>. Figure 7 indicates that the radiation resistance of monopole antennas is length dependent. Resonance of a quarter-wavelength monopole occurs when its length is slightly less than a quarter-wavelength.

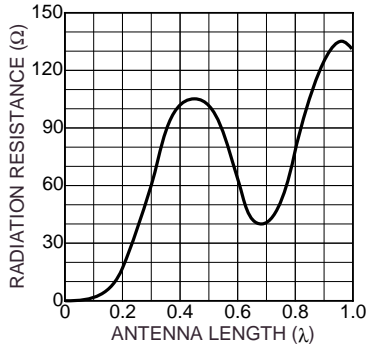

**Figure 7. Radiation Resistance of Monopole Over Ground Plane**

Length of a resonant quarter-wavelength monopole antenna made of wire may be calculated from the following equation which takes into account the slight shortening for resonance:

$$\text{length} = \frac{2808}{\text{frequency}}$$

where:

length = inches  
frequency = MHz

**To design a monopole antenna, simply calculate the appropriate length, cut a wire, and attach directly to the ANT (antenna) pin of the MICRF001. That's all there is to it.**

For example, the appropriate length for a quarter-wave monopole at 433.92MHz would be  $2808 \div 433.92 = 6.47$  inches. Sophisticated antenna measurements are generally not necessary unless a highly optimized design is desired. This makes the monopole very popular and easy to apply.

**Helical Antennas**

A helical (coil) antenna is shown in Figure 8. Helical antennas may be constructed from copper, steel, or brass; from an electronic component standpoint, it is simply an inductor. Compared to the monopole, which is essentially a two-dimensional structure, the helical antenna is a 3-dimensional structure. As stated earlier, a monopole can be thought of as a "stretched-out" helical antenna. Helicals are difficult to analyze because of their 3-dimensional nature, and are usually empirically optimized.

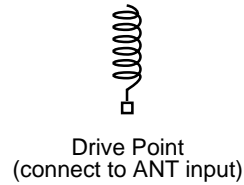

**Figure 8. Helical Antenna**

Helical antennas are characterized as either small helicals, which operate in normal mode, or large helicals, which operate in axial mode. By axial or normal, we convey the direction of the radiation pattern: axial being along the axis of the helix, and normal being at right angles to the helix axis. A helical antenna is small if its diameter and length are both much smaller than one wavelength. **Helical antennas used with the MICRF001 are almost exclusively small helicals, with a normal radiation pattern.**

Figure 9 illustrates the radiation pattern of the small helix. We observe the radiation pattern is similar in nature to the monopole, and is also fairly insensitive to dimensional changes, provided such changes are much smaller than a wavelength.

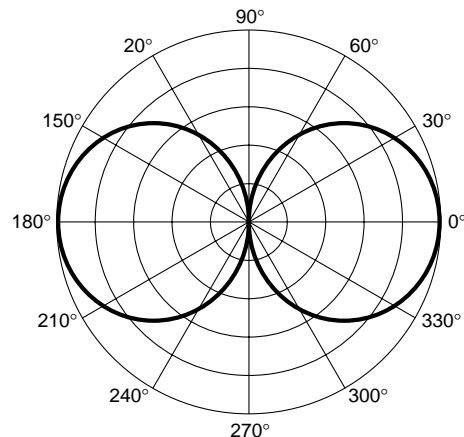

**Figure 9. Helix Radiation Pattern**

Terminal impedance of the helical antenna is far less well characterized, simply because the impedance depends on numerous parameters: coil diameter, coil loop pitch, coil length (or number of turns), and frequency. Variations in any of these parameters can “detune” the antenna away from resonance. For this reason the helical antenna is considered to be more narrow-band than the monopole. **As a result, designing and optimizing helical antennas is usually done empirically. But even with this shortcoming, the helical is very popular, since it provides reasonable range and very small size.**

Radiation from small helical antennas is fundamentally elliptically polarized. A good discussion on the design of helical antennas and coils is given in *Reference Data for Radio Engineers*<sup>2</sup>, Chapter 27, pages 27-11 through 27-13 and *The Design of Impedance Matching Networks...*<sup>5</sup>, Section 2.3.6. Helical antennas are commonly found on LC (inductor-capacitor) transmitters, where the L (helical coil) is both a part of the resonant network and the antenna—a very inexpensive solution.

**Unfortunately, no simple expression exists for the design of a helical antenna, like exists in the previous section for the monopole. It is possible to calculate the length of a (resonant) helical once its diameter, coil spacing, and material type are known. In most cases, however, it is just as easy to arrive at a design empirically by taking an overly long coil, and tuning it by clipping away pieces until the antenna is resonant at the desired frequency. Strictly speaking, this will require a piece of specialized test equipment, such as a network analyzer. Otherwise, trim the structure for maximum range.**

### PCB Loop Antennas

Loop antennas are perhaps the least used antenna at the receiver. These antennas have very low radiation resistances and must be relatively large to be efficient signal collectors, an important attribute at the receiver. Figures 10a and 10b illustrate the radiation pattern and radiation resistance of the loop antenna, respectively. Radiation resistance is given as a function of  $C_\lambda$ , the loop circumference in wavelengths. Even for  $C_\lambda = 0.5$  wavelengths, the radiation resistance is under  $10\Omega$ .

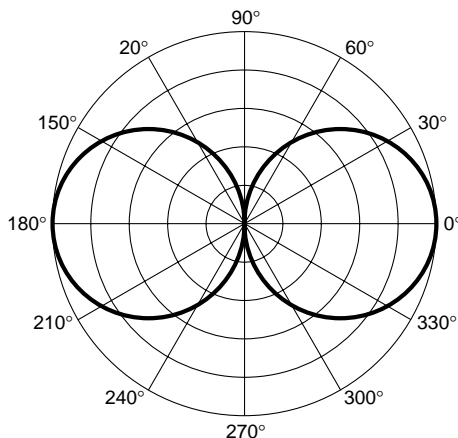

Figure 10a. Loop Radiation Pattern

The radiation pattern for a small loop is similar to those of both the small helical and quarter-wave monopole. Polarization of

the loop antenna is fundamentally circular. Finally, when the loop area  $A < 0.01\lambda^2$ , square and circular loops can be treated identically as long as the areas of the two loops are the same. This means that for small loops it is not at all important that the loop be circular, but it can be any closed loop structure.

**Loop antennas find applications mostly at the transmitter, especially where ruggedness, size, and ease of construction are required.**

**A good application for the loop antenna is the push-button transmitter which attaches to a key chain, for RKE (remote keyless entry) applications. Such designs must be rugged, cheap, very small, and fully integrated. Further, the typical packaging is elliptical or circular in nature, allowing a loop antenna to be constructed around the periphery of the assembly with little additional impact to PCB space.**

**To construct a loop antenna, make the loop as large as possible, then simply “tune” the antenna to resonance with a parallel capacitor. Typical values are 1pF to 5pF in the UHF band, and the capacitor may be fixed or variable depending on the application.**

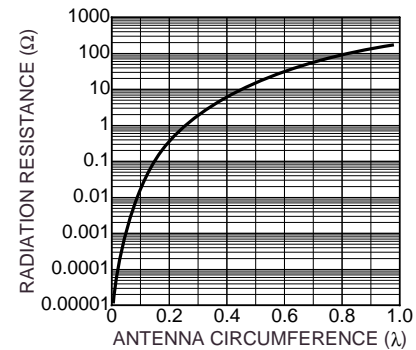

Figure 10b. Loop Radiation Resistance vs. Loop Circumference

### Impedance Matching

Where electrically small antennas (that is, physical dimensions significantly less than 1 wavelength) are connected directly to the MICRF001 ANT pin, the structure can be treated as a lumped circuit. This is because the phase across the antenna is negligible. In such instances, impedance matching the antenna to the IC will not improve system range. **In applications where the antenna and IC are collocated, impedance matching is not required.**

In applications where the antenna is located away from the IC, they must be interconnected using a transmission line. A transmission line is simply a way of conveying a signal between two points without distortion or loss, as the line provides constant incremental impedance<sup>4</sup>. For the transmission line to function properly, the antenna impedance must be “matched” into the transmission line impedance at one end and the transmission line “matched” to the IC impedance at the other end. A commonly used type of transmission line is coaxial cable which is available in a number of standard impedance values.

The concept of transmission line matching is too extensive to be covered in detail in this section. Impedance matching is

generally regarded as an RF engineering problem, and there are entire textbooks devoted to the subject.

**Users who require the antenna to be remote from the IC, and don't already possess impedance matching expertise, should seek outside guidance. Several references for constructing matching networks<sup>4,5</sup> are provided in the bibliography. If it is at all possible, Micrel recommends that the antenna be attached directly to the IC to avoid impedance matching issues.**

## Multipath Fading

Multipath fading is a form of signal fading caused by signals arriving at the receive antenna with differing phases. This results because signals from the transmitter may follow different paths in traveling to the receiver. Portions of the original signal may travel in a direct path, while others may arrive at the receiver by reflecting off ground or other objects in the locale. These differences in phase result in constructive and destructive interference at the receiving antenna, which affects the amplitude of the signal developed at the antenna. While a solution exists for this problem (called diversity switching with multiple antennas), it is usually cost-prohibitive for MICRF001 applications.

Antenna testing is usually performed in an open field as a way of keeping multipath fading from corrupting the measurement process. Multipath fading effects are not related to the antenna, but to the local environment. While there is little one can do to mitigate the problem, it is important that the user understand that multipath fading will cause system range variations from site to site.

## Antenna Testing and Measurement

An antenna's theoretical and measured characteristics can vary widely, due to factors such as ground plane, antenna orientation, form-factor changes, and proximity to other objects in the product assembly. Further modifications arise from objects at the installation sites, and elicit multipath fading, for which little can usually be done. In many cases, designers of MICRF001-like applications just empirically optimize their antenna systems. If this is not adequate, more thorough methods do exist to measure an antenna's characteristics. Such methods are too extensive to be completely covered here, and can be found in numerous references, for example, *Antennas*, Chapter 15. Unfortunately, such measurements require an RF expertise and more sophisticated test equipment. An alternative, if cost permits, is to "contract out" such antenna characterization work. This will greatly improve the chances that the work will get done right the first time.

## Bibliography

1. Kraus, J. D., *Antennas*, McGraw-Hill Co., 1950. ISBN 07-035410-3
2. *Reference Data for Radio Engineers*, 6th ed., compiled by ITT (International Telephone and Telegraph), Howard W. Sams and Co. Publishers, 1968. Library of Congress No. 75-28960
3. Jasik, H., *Antenna Engineering Handbook*, McGraw-Hill Co., 1961
4. Caron, W. N., *Antenna Impedance Matching*, ARRL Press, 1989. ISBN 0-87259-220-0.
5. Abrie, P. L. D., *The Design of Impedance-Matching Networks for Radio-Frequency and Microwave Amplifiers*, Artech House, Inc., 1985. ISBN 0-89006-172-6.

---

**MICREL INC. 1849 FORTUNE DRIVE SAN JOSE, CA 95131 USA**

TEL + 1 (408) 944-0800 FAX + 1 (408) 944-0970 WEB <http://www.micrel.com>

This information is believed to be accurate and reliable, however no responsibility is assumed by Micrel for its use nor for any infringement of patents or other rights of third parties resulting from its use. No license is granted by implication or otherwise under any patent or patent right of Micrel Inc.

© 1999 Micrel Incorporated